

# IF YOU...

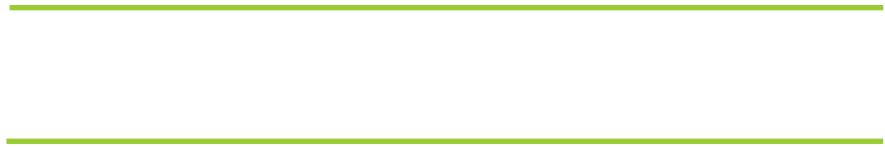

MIX IT. FILL IT. PACK IT. SHIP IT.

# WE HAVE A PRODUCT FOR YOU



Part #	26B7DT
Load Capacity	1,000 lb.
Drum Type	Poly Drums
Wheel Type	(2) 10" x 2.25" Solid Polyolefin
Dimensions	23-3/4"W x 24"L x 59-3/4"H
Weight	67 lbs.
Pallet Pack	4 ea.
Model	40BTW



240076

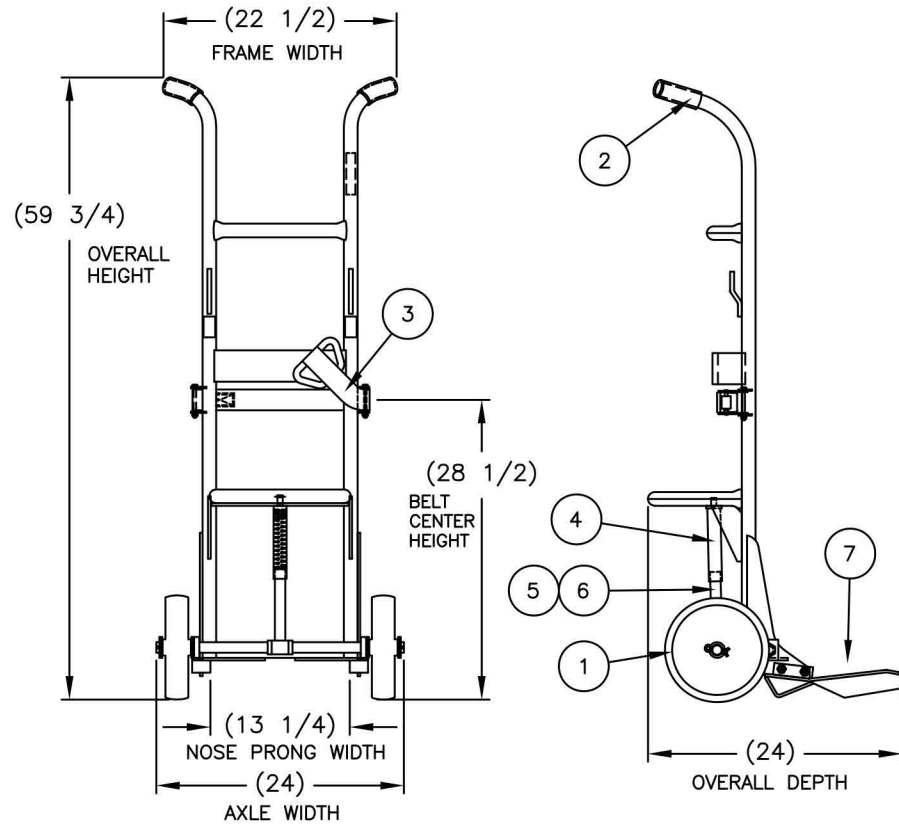

P/N **240076**  
 Model: **40BTW**  
 Capacity: 1,000 lbs  
 Weight: 67 lbs  
 Wheel: 10" x 2-1/4" Polyolefin

**REPLACEMENT PARTS LIST**

1	150691	WHEEL: 10 X 2-1/4" poly	2
	108208	WASHER: FLAT 1" SAE	4
	108218	COTTER PIN 3/16 X 1.5"	2
2	108433	HANDGRIP: YELLOW 1-1/4"	2
3	150303	STRAP: W/HANDLE, ASS'Y	1
	108900	SCR: HEX HD 1/4-20 x 3	2
	108929	NUT: LOCK 1/4-20	2
4	051346	UPPER SPRING HOUSING	1
5	051347	ASS'Y: FLOATING AXLE	1
6	051356	SET: HARDWARE, AXLE	1
7	240115	SET: NOSE PAD	1
8	-	BOX	

**DRUM TRUCK Features:**

- Industrial strength heavy duty 1" structural pipe frames.
- All joints double welded.
- High quality cast iron center moldon rubber wheel with 1" (ID) roller bearings.
- Polyolefin wheel is cost competitive and resistant to most environments that may damage rubber wheels.
- All trucks can be stored standing upright.
- Engineered to handle 55 gallon steel drum.
- capacity: 1,000 lbs.

**40BT/40BTW Features:**

- Handles all poly and fiber drums except overpacks (use 45BT)
- Replaceable "feet" and belt.
- Floating axle reduces effort required to break over and balance load.
- 24" depth
- With wheels resting on floor, 28.5" center of belt.

PRINT ISSUED

NOV. 10, 2006

ENGINEERING DEPARTMENT

The **CARY COMPANY**  
 Est. 1895

R W S	APP	REV	ECN & DATE	REVISIONS	PART NAME	DRAWN: LDU 8-9-00		
					<b>40BTW</b> DRUM TRUCKS	CHECKED:		
10-22-12 UPDATED	J	REV			TOLERANCE UNLESS OTHERWISE SPECIFIED	APP. ENGR.		
					FRACTION	3 PLACE DECIMAL	2 PLACE DECIMAL	SCALE: 1" = 12"
					± 1/64	± .005	± .01	
					ANGULAR ± 1-1/2°	SHEET 1 OF 1		<b>B- 240076</b> REV <b>B</b>
BREAK ALL SHARP EDGES AND REMOVE ALL BURRS								