

IF YOU...



MIX IT. FILL IT. PACK IT. SHIP IT.

WE HAVE A PRODUCT FOR YOU



Drum Lifter/Dispenser w/Tipping Handle for
55 Gallon Steel Drum (800 lb. Capacity)

Product Category: Drum Lifters

Part #	26BDL3
Material	Steel
Dimensions	29" L x 8.5" W x 36" H
Pallet Pack	6 ea.
Country of Manufacture	United States
Model	DL-55
Weight	45 lbs.

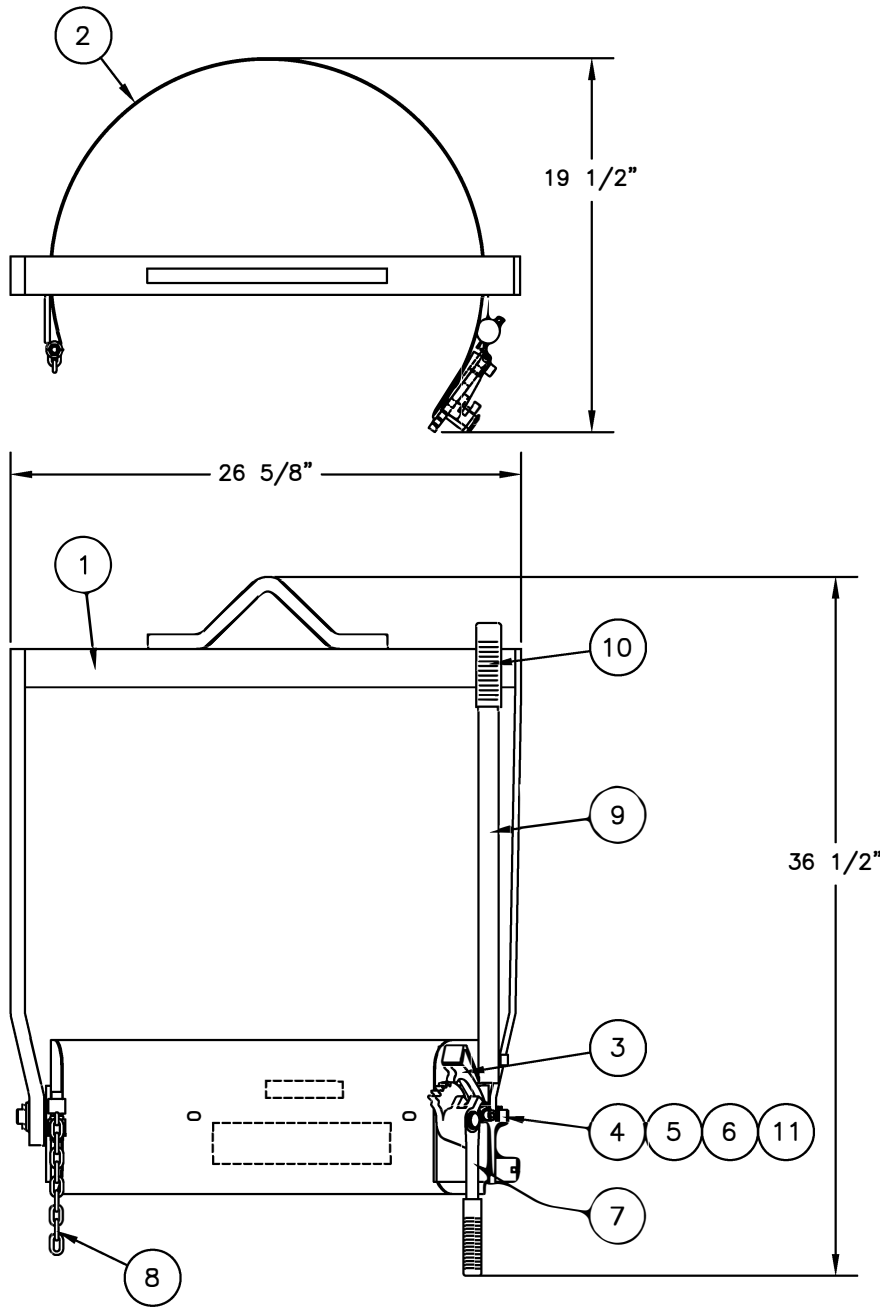

REPLACEMENT PARTS LIST			
1	054097	WELDMENT: FRAME DL-55	1
2	054061	WELDMENT: SADDLE DL-55	1
3	270411	KIT: TIGHTENER CLAW	1
	150321	CLAW	1
4	053741	PLUNGER: DL-55/ML-55	1
5	108470	SPRING: COMPRESSION	1
6	108599	PIN: SPRING 3/16 DIA. X 3"	1
7	051991	ASS'Y: RATCHET HANDLE	1
	054071	RATCHET: CASTING	1
	101242	HANDGRIP, BLACK	1
8	053417	CHAIN: SADDLE (36")	1
	101107	CHAIN	3.03'
9	054063	HANDLE: TURNOVER	1
10	108226	HANDGRIP: BLACK 1"	1
11	151219	PIN: HAIRPIN STYLE .148 X 4"	1
* 12	109703	BOX: DL-55/30	1
OPTIONS			
	270040	30 GALLON CONVERTER KIT (DL,DGL,ML)	1
	270402	FBA: ADAPTER DRUM LIFT/CARRIER	1

* not shown

STANDARD DRUM LIFTER DISPENSER

- Easily lift drum and dispense contents.
- Handles 55 gallon steel drums.
- Locks in horizontal or vertical position.
- Ships assembled and boxed.
- Economical, lower capacity VALVE product also available

** TIPPING HANDLE AVAILABLE ONLY ON DL-55 MODEL

P/N 240032
 Model: DL-55
 Capacity: 800 lbs (full drum)
 500 lbs (half drum)
 Weight: 45 lbs
 Color: Orange
 Boxed: Yes

PRINT ISSUED
 JUNE 07 2007

The **CARY COMPANY**
 Est. 1895

R W S APP	12-13-12 K UPDATED	REV. CHG. & DATE	REVISIONS	DL-55		DRAWN: LDU 5-11-00	
				TOLERANCE UNLESS OTHERWISE SPECIFIED		CHECKED:	
				FRACTION	3 PLACE DECIMAL	2 PLACE DECIMAL	APP. ENGR.
				± 1/64	± .005	± .01	SCALE: 1" = 5"
ANGULAR ± 1-1/2°	SHEET 1 OF 1		C-240032	REV	K		
BREAK ALL SHARP EDGES AND REMOVE ALL BURRS							