

# IF YOU...



MIX IT. FILL IT. PACK IT. SHIP IT.

# WE HAVE A PRODUCT FOR YOU



Salvage Drum Lifter for 55-85 Gallon Tight Head Steel Drums (1000 lb. Capacity)

*Product Category: Drum Lifters*

Part #	26BDL9
Material	Steel
Dimensions	19.63" L x 9.88" W x 7.38" H
Pallet Pack	32 ea.
Country of Manufacture	United States
Model	SDL-85
Weight	20 lbs.
Load Capacity	1,000 lbs.
Note	Hoist is not included

240102

REPLACEMENT PARTS LIST

1	051792	ARM SUPPORT WELDMENT	1
2	051798	PIVOT ARM WELDMENT	1
*	053431	HARDWARE: BAGGED	1
	108890	CLEVIS PIN	1
*	108870	BOX: SDL-55/85	1

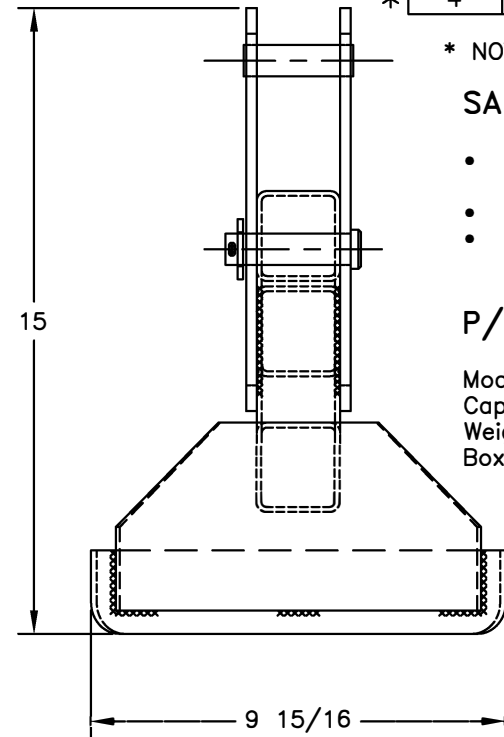
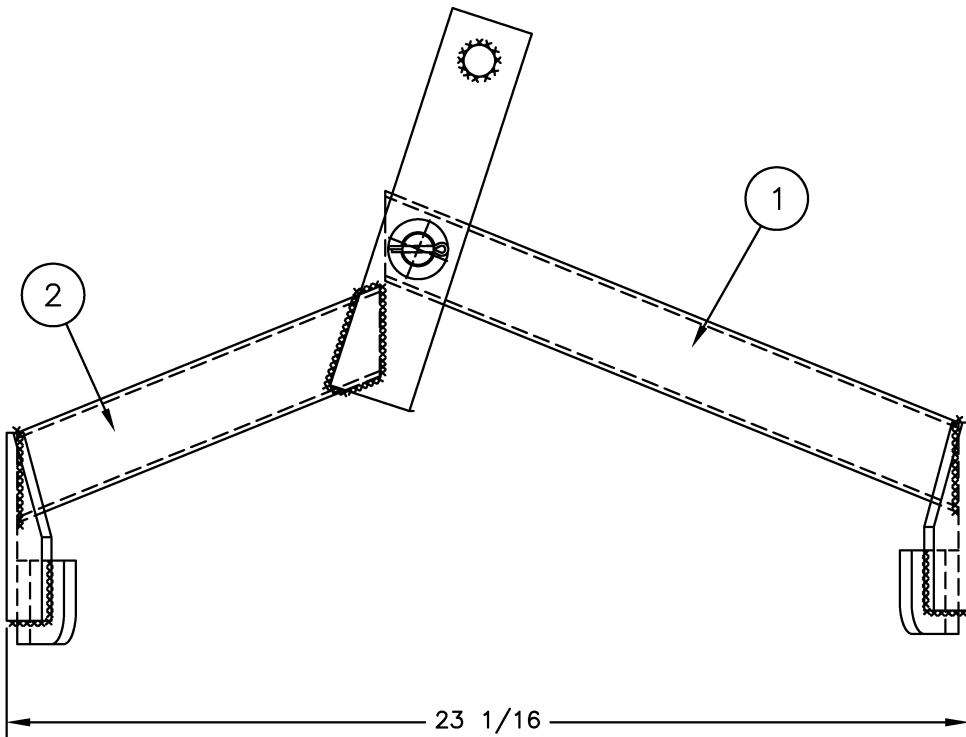

\* NOT SHOWN

SALVAGE DRUM LIFTERS

- Convenient for fast and gentle loading of steel drums into overpacks.
- Ships boxed via UPS.
- For use with closed head steel drums.

P/N 240102

Model **SDL-85**  
 Capacity 1,000 lbs  
 Weight 18 lbs  
 Boxed YES

PRINT ISSUED

DEC 29, 2006

The **CARY** COMPANY  
 Est. 1895

R W S  
 12-04-12  
 C UPDATED

APP	PART NAME	SDL-85	DRAWN: CY 2-12-91
REV	EDN & DATE		CHECKED: DS 2-18-91
REVISIONS	TOLERANCE UNLESS OTHERWISE SPECIFIED		APP. ENGR.
	FRACTION 3 PLACE DECIMAL 2 PLACE DECIMAL		SCALE: 1:3
	± .005 ± .005	1	B- 240102
	ANGULAR ± 1-1/2"	SHEET 1 OF 1	REV C
	BREAK ALL SHARP EDGES AND REMOVE ALL BURRS		