

# IF YOU...



MIX IT. FILL IT. PACK IT. SHIP IT.

# WE HAVE A PRODUCT FOR YOU



---

---

Part #	26BGF2
Gasket	EPDM Rubber Gasket
Material	PP
Model	SCP6500.200.EPDM
Note	**While the pump is compatible with over 1300 chemicals, please specify the product you will be dispensing with the pump to ensure seal compatibility.



## Pump assembly overview



Please read all instructions thoroughly before beginning assembly. We have found this to be of great value when assembling your first pump. Each step below has step-by-step instructions on the following pages.

1. Select and install adapters or fittings on to the container.
2. Select and install drum seal on to the pump.
3. Assemble the siphon tube to the correct length.
4. Install the pump onto the fitting or container.

### 1. Select and install adapters or fittings on to the container.

Examine the opening of your container to decide what you have. Common openings and their fittings are described below. Follow installation instructions on the packaging which accompanies each adapter.

#### Pump Standoff

If using the pump with a 20, 30 or a 55 Gallon container with 2" npt opening, please use the provided 4" standoff kit. Without it, the spout can hit the edge of the container. Use of the Standoff will also give the drum seal a much longer life.



#### Buttress Adapters

You may have containers which have a coarse thread - such as you see here. The drum seals are not pliable enough to work with these large threads. There are buttress adapters for these special openings: 2.25" for most Asian manufactured drums, 2.5" for most U.S. drums, and 2.75" for most European drums. These adapters are sold with a large o-ring to assist with the seal on the container.

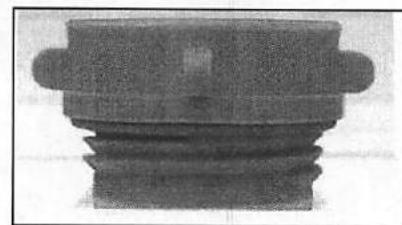

2.5" Adapter

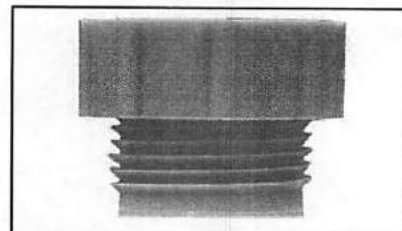

2.25" Adapter

**Rieke® Flex Spout® Adapter**

This adapter allows the pumps to be used on containers which feature a Rieke® FlexSpout® or the Rieke FSII. This eliminates tipping of the container and associated spill hazards. Supplied with Nitrile washer as standard, EPDM and Viton® washers are also available.

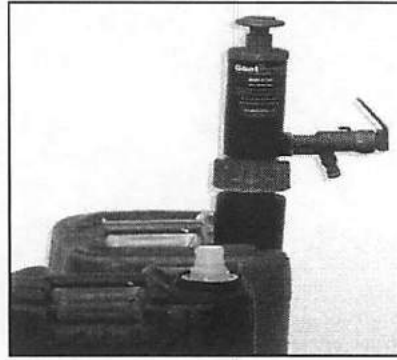
**Metal Can Adapter**

This adapter allows the pumps to be used on metal containers which feature an external thread. Dimensions of opening on container are approximately 54mm O.D. and 38mm I.D. Supplied with Nitrile washer as standard, EPDM and Viton® washers are also available.

**83-B Adapter**

This adapter allows the pumps to be used on containers such as Nalgene which have an 83mm external thread. Supplied with Nitrile washer as standard, EPDM and Viton® washers are also available.

**12 Inch Standoff**

The 12-inch standoff allows the receiving container to be placed on top of the drum for easier transfer.

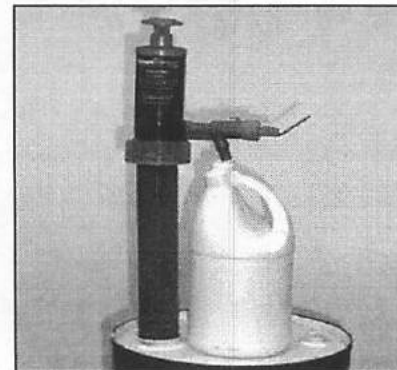

## 2. Installing drum seal on the pump

Drum seals are provided in one or three sizes depending on the model you have. Be sure to choose the size seal which most closely fits the container opening, standoff or other specialty fitting. If none of the three sizes can form a tight seal, the container cannot be used with pump.

### Drum seal sizes

Small seal.....1.8" (44.4 mm)    Medium seal .....2.0 (52.5 mm)  
 Large seal.....2.25" (56.5 mm)

**1** Select drum seal which is the closest fit to the opening on the container, standoff, buttress or other fitting.

### 2 Apply grease to pump lip

Apply a very small amount of Molykote 111 or other silicone grease to the bottom lip to improve ease of installation of drum seal.

For clean room installation, do not use grease. Soak drum seal in hottest water available for 2-5 minutes until it is pliable.

**3** Make sure drum seal expander is fully retracted.

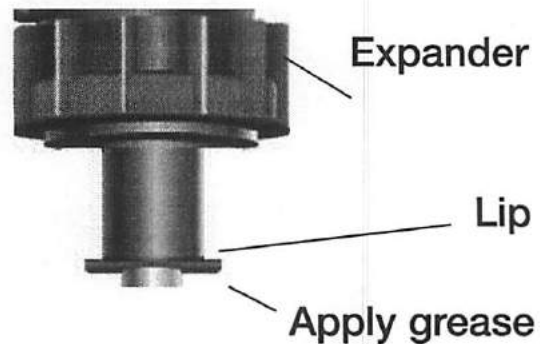

### 4 Put the drum seal on

Push the drum seal completely over the lip. Make sure the seal rests on top of the lip and flush to the retaining disk. Sometimes, using the palm of the hand to push the seal on gives the best results. You will have to push quite hard to get the seal over the lip. The rubber will not break. Squeeze the drum seal around the lip to seat it completely on top of the lip.



Seal sits on top of lip

**WARNING:** The drum seal must be completely on the top of the lip or the pump won't work.



Remove any visible grease or liquid from the drum seal, lip and wall of adapter or container opening to prevent the pump from unintentionally ejecting out of the container when pressure is added.

### 3. Assemble and install the siphon tube

#### 1. Assemble siphon tube

Measure container depth and assemble siphon tube segments as needed. Segments can be cut. Tubes and connectors must be assembled tightly together.

#### 2. Fit foot piece to siphon tube

Attach foot piece to bottom length of siphon tube (portion nearest bottom of container). This piece helps prevent clogging and maintains proper fluid flow.

#### 3. Determine final length of tube

Final assembled length should be cut to 1/2 inch higher than the top of fitting or drum so that tube is wedged firmly between pump and the bottom of the container when installed.

Failure to do so may result in loss of siphon tube in drum.

First pump segment must be inserted and then twisted at **least 1 inch** into pump body to secure it.

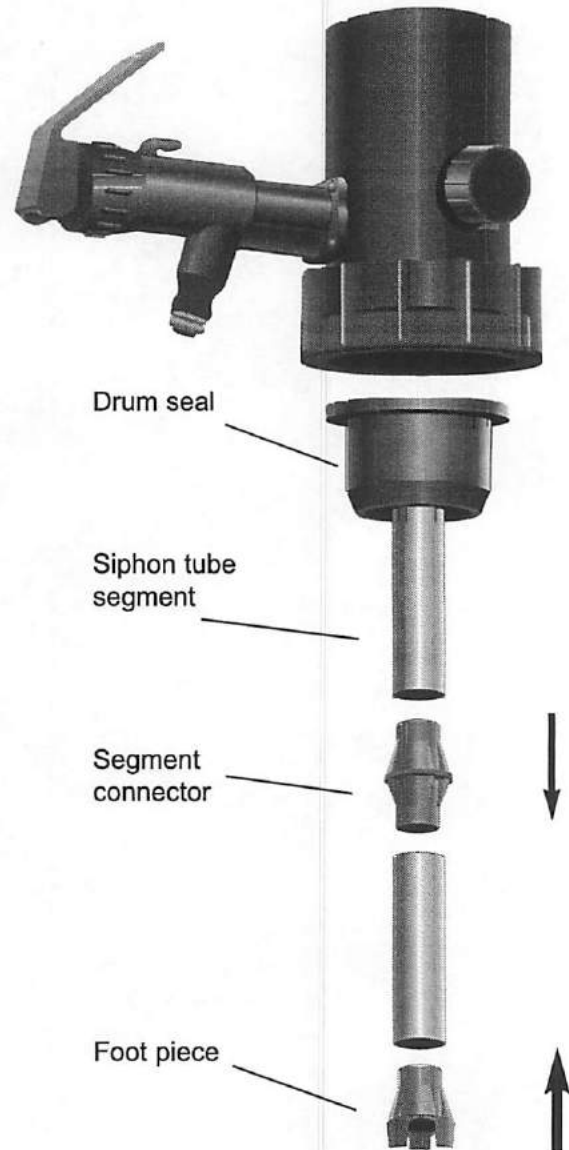

**CAUTION:** Insert siphon tube as far as it will go into the pump, and join all parts tightly and securely so the siphon assembly cannot come apart inside the container.

Failure to follow these directions may require you to purchase an additional siphon tube kit.

**4. Fit pump to container, standoff or other fitting** Before fitting the pump to any container or fitting, make sure both the drum seal and the container neck or fitting opening are clean and free of contaminants or grease that could prevent an air-tight seal or allow pumps to slip out after adding pressure.

**1 Loosen drum seal expander**

Loosen seal expander completely (turn fully counterclockwise).

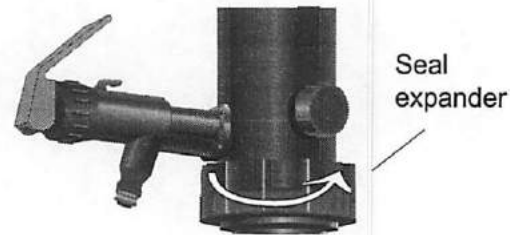

**2 Insert pump**

Insert drum seal fully into standoff, container neck opening or other fitting. Make sure siphon tube is long enough to firmly extend from the bottom of the container to 1/2 inch above standoff or container opening.

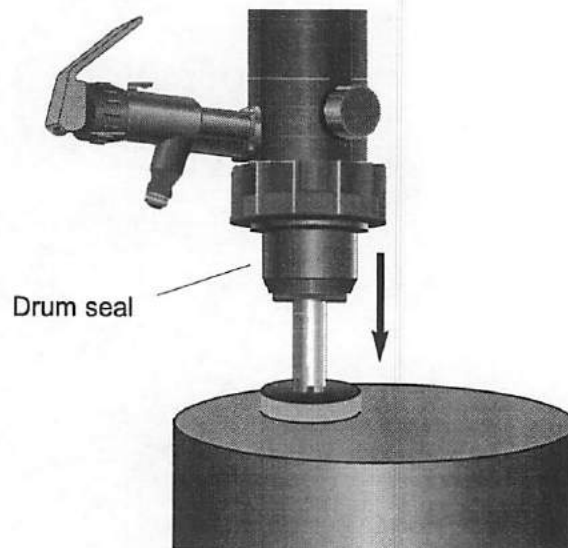

**3 Tighten collar**

Keeping pump firmly pressed down, tighten seal expander until firmly fitted to container neck opening.

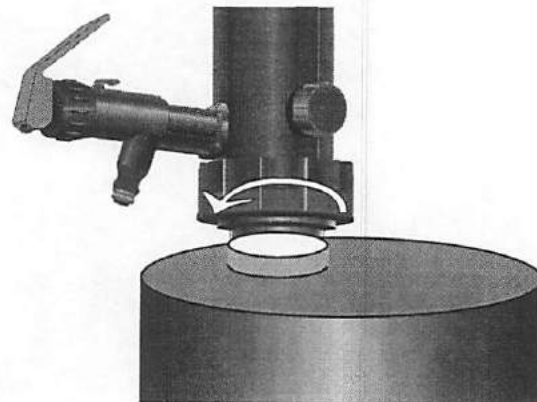

**4 Check fit**

Check fit by attempting to gently pull the pump up and away from the container. If properly fitted, the pump should remain firmly attached.