

IF YOU...

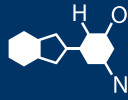

MIX IT. FILL IT. PACK IT. SHIP IT.

WE HAVE A PRODUCT FOR YOU

Part #26W3PV

Tri-Sure Plastic Drum Plugs (for Steel)

3/4" Tri-Sure® PP Drum Plug with Vent, EPDM Gasket



The
CARY COMPANY
Est. 1895

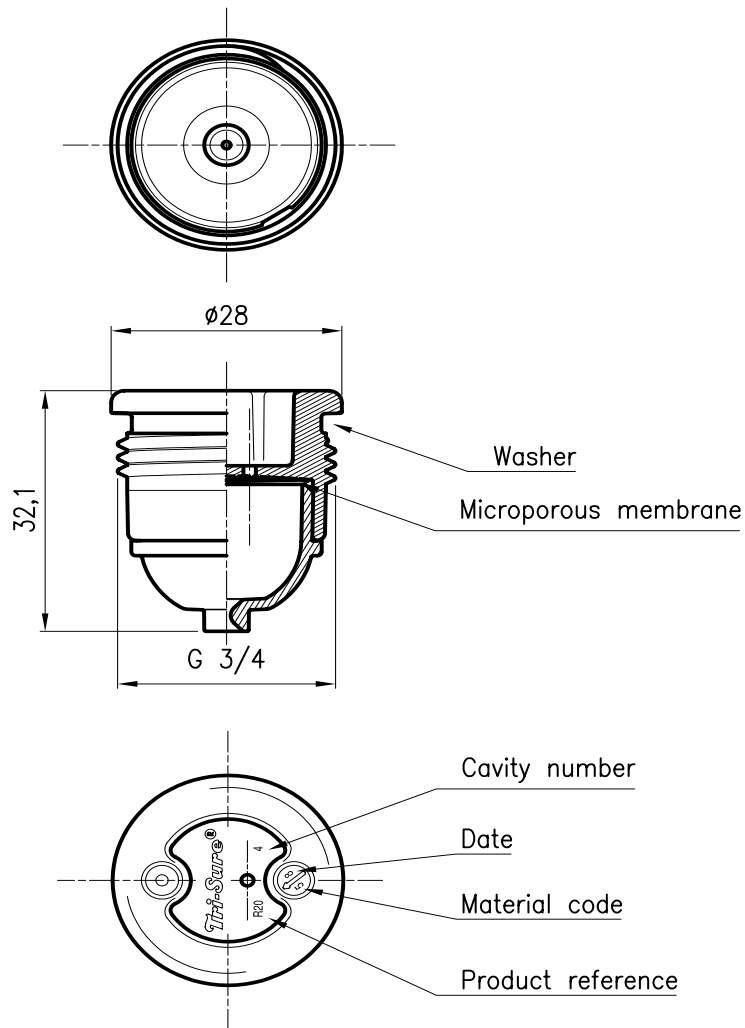

1	Bulb	.	PP Copolymer	Yellow
1	Microporous membrane	.	GAZ016	—
1	G3/4 Tri-Sure(R) plastic plug	R20	PP Copolymer	Yellow
Qty	Description	Product reference	Material	Std colour
		Title: G3/4 Tri-Sure plastic plug – microporous membrane		
		Customer Drawing: TSF-504547	Rev: 2 Date: 27-06-2008	Scale: 1:1 Size: A4
This drawing is our property and is confidential. It must not be copied or shown to third parties. Printed versions are uncontrolled.				

PERFORMANCE CHARACTERISTICS OF VENTS Selection Guide

Purpose of Venting

The purpose of venting a package can be:

- To relieve overpressure caused by gassing of the filling product (e.g. hydrogen peroxide)
- To relieve under pressure caused by cooling down of a drum after hot filling (e.g. high viscosity liquids)
- To prevent unsafe stacking conditions of light weight packages as a result of pressure changes caused by temperature variations.

Range of Standard Vents

Valve Type Vents

The standard valve type vents are made of high-performance rubber. The functional operation of this type of vent is based on pre-tensioning of the stem of the vent and allowing re-closing after over- or under pressure has occurred. Rubber mushroom and umbrella vents are available for Tri-Sure[®] plastic and steel plugs in many executions.

Membrane Type Vents

The standard microporous membranes (MPV) type vent consists of a P.T.F.E. (Teflon) backing and is available in G³/₄ Tri-Sure plastic plug execution provided with a protective bulb. This in turn can be assembled into a Tri-Sure combination plug or a Tri-Sure vented Screwcap. For special applications insert type vents are also available. By nature, the membrane is liquid repellent and allow the container to breathe while preventing the ingress of moisture or foreign matter.

Performance

The performance of a vent system can only be guaranteed when located above the liquid surface and not affected by the contents of the drum or any other foreign material that can block the outlet vent opening. The performance of the standard vent is as indicated in the table above.

Compatibility

It remains the responsibility of the user to check if all requirements in the law and regulations are met e.g. product filling, safety and transportation. Chemical compatibility testing should be conducted under laboratory and in actual use of the vent-closure system.

Vent Type	Average Opening Pressure in Bar	Average Air Flow Rate in ml/min. at 0.2 Bar Pressure
Umbrella or Mushroom	0.1	1000
Microporous Membrane	(almost) 0	1500 minimum

Selection Guidelines

- Step 1 Verify whether the relevant Regulation/ Recommendations permit venting of the package in the specific intended application.
- Step 2 Determine whether the requirement of venting is uni- or bi-directional. When bi-directional venting is not allowed, membrane type vents are not suitable.
- Step 3 Check if venting is required below the threshold opening pressure of a valve type vent.
- Step 4 Check the maximum temperature requirements. For hot-filling of highly viscous products, where venting-in during cooling down of the drum is required, a steel plug with a valve type vent is advised when the filling product is not sensitive to ingress of foreign material.
- Step 5 Check the chemical compatibility (see para. 5) in combination with the required venting performance.

Regulations

Reference is made to the following statements in para 9.3.8 of the UN Recommendation on the Transport of Dangerous Goods. 'Where pressure may develop in a package by the emission of gas from the contents (as a result of a temperature increase or other cause), the packaging may be fitted with a vent provided that the gas emitted will not cause danger on account of its toxicity, flammability, the quantity released, etc. Venting of the package should not be permitted for air transport' Where the risk exists of ingress of foreign material into the drum the packager should verify whether this is acceptable for the product to be filled. The performance of vents may be impaired if contaminated by the filling product (see also para. 5.1 and 5.2).

Cautionary notes!

- ☞ Only vented Tri-Sure[®] Tab-Seal[®] are allowed on vented closures.
- ☞ Always store upright.
- ☞ Store under cover.
- ☞ Air transport is not permitted.
- ☞ Check National Regulations for local requirements.

For details contact our local Tri-Sure[®] Sales & Support center.