

# IF YOU...

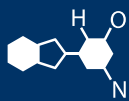

MIX IT. FILL IT. PACK IT. SHIP IT.

# WE HAVE A PRODUCT FOR YOU

Part # 26WAD2

---

---



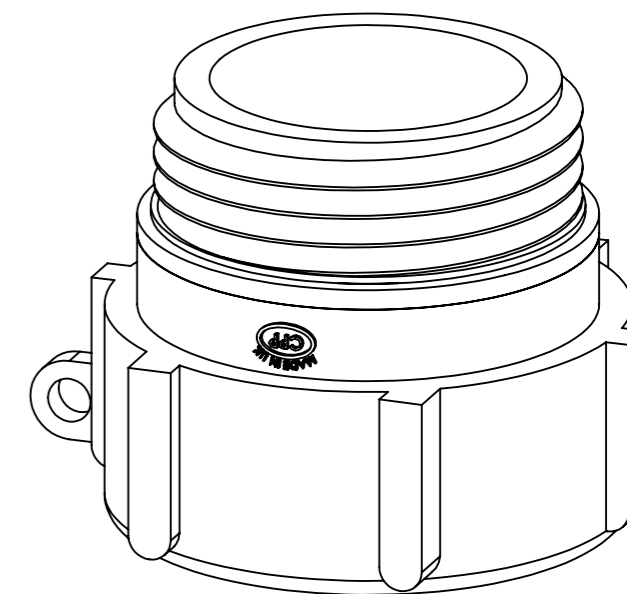
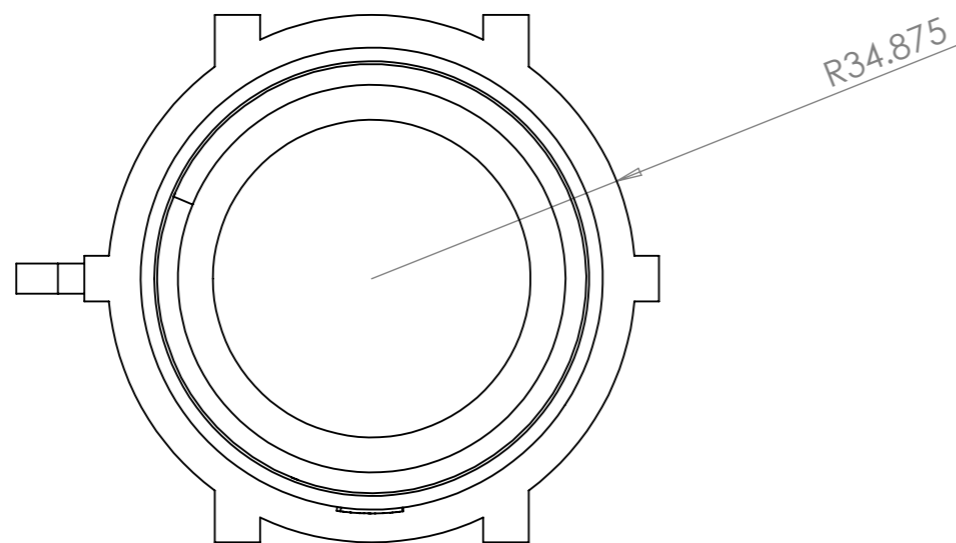
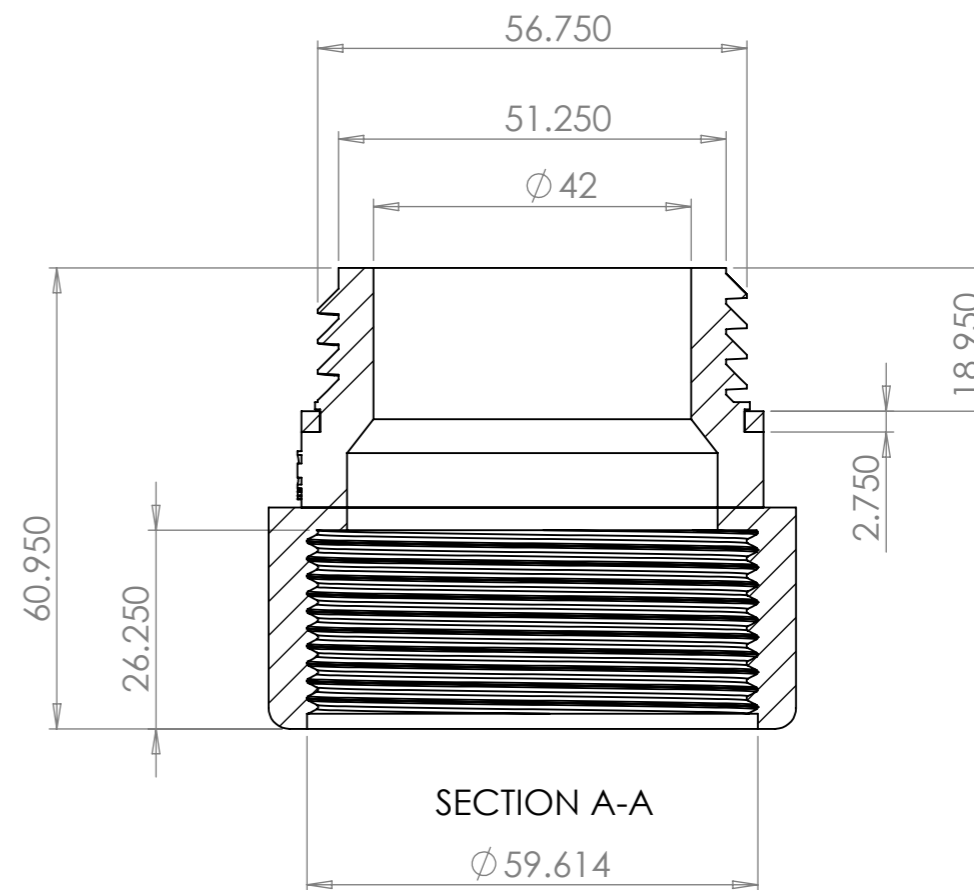
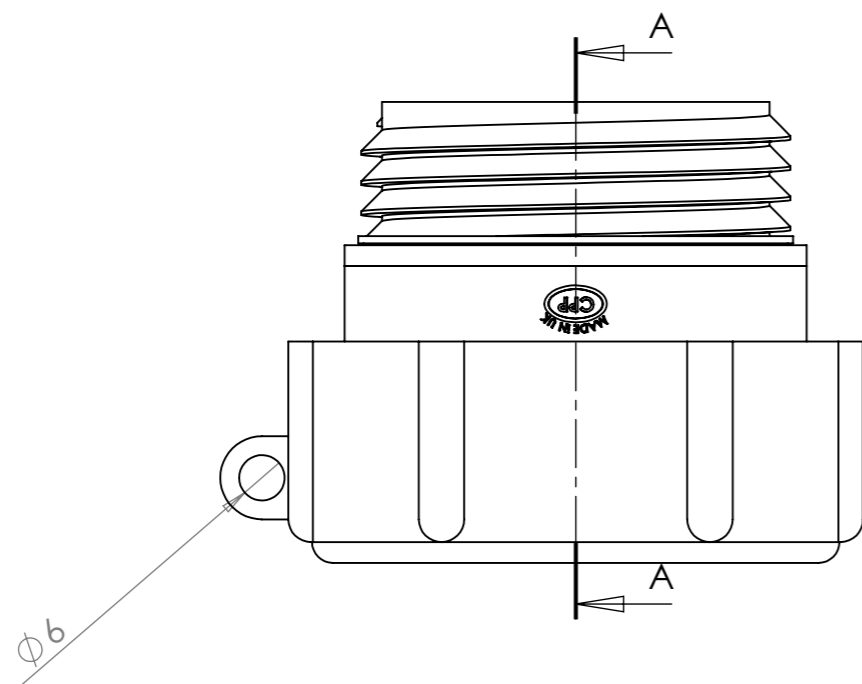

UNLESS OTHERWISE SPECIFIED: DIMENSIONS ARE IN MILLIMETERS SURFACE FINISH: TOLERANCES: LINEAR: ANGULAR:			FINISH:		DEBURR AND BREAK SHARP EDGES		DO NOT SCALE DRAWING		REVISION		
DRAWN JULIAN TROUGHT			SIGNATURE		DATE 31.05.13		TITLE: S56X4 male drum thread x 2" BSP female				
CHK'D							DWG NO.				A3
APPV'D							MATERIAL: POLYPROPYLENE				
MFG							WEIGHT:				SCALE:1:1
Q.A							SHEET 1 OF 1				