

IF YOU...



MIX IT. FILL IT. PACK IT. SHIP IT.

WE HAVE A PRODUCT FOR YOU



30 Gallon Steel Drum, UN Rated, Cover w/
Lever Lock Ring Closure, 2" & 3/4" Fittings

Product Category: Open Head Steel Drums

Part #	26WD30
Capacity	30 gal.
Condition	New
Color	Black w/ White Cover
Material	Carbon Steel
Closure	Cover w/ Lever Lock Ring Closure
Lining	Rust Inhibitor Enamel
Steel Thickness	1.2/1.2/1.2 (Top/Body/Bottom)
Steel Gauge	18/18/18 (Top/Body/Bottom)
Fittings	2"NPT & 3/4" NPT
Gasket	EPDM Rubber Gasket
Dimensions	18.25"Dia. x 26.7"H (inside) 18.8"Dia. x 29"H (outside)
UN Rating Solid	UN1A2/X235/S

500300

ECN # or INIT	REV	DESCRIPTION	DATE
OE-005	A1	REDRAWN TO AutoCAD	03-MAY-2010
OE-001	A2	CLERICAL ERROR	29-MAR-2013
OE-001	A3	ADDED CHIME VIEW	29-APR-2013

SECTION A-A

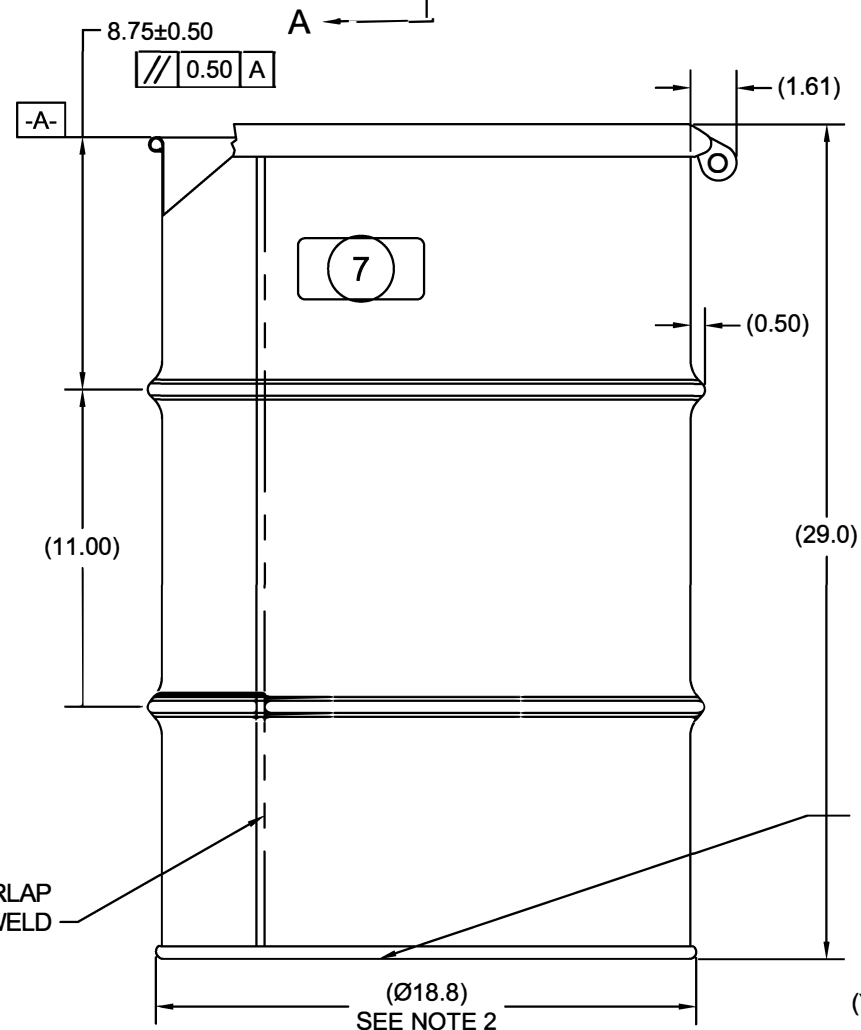
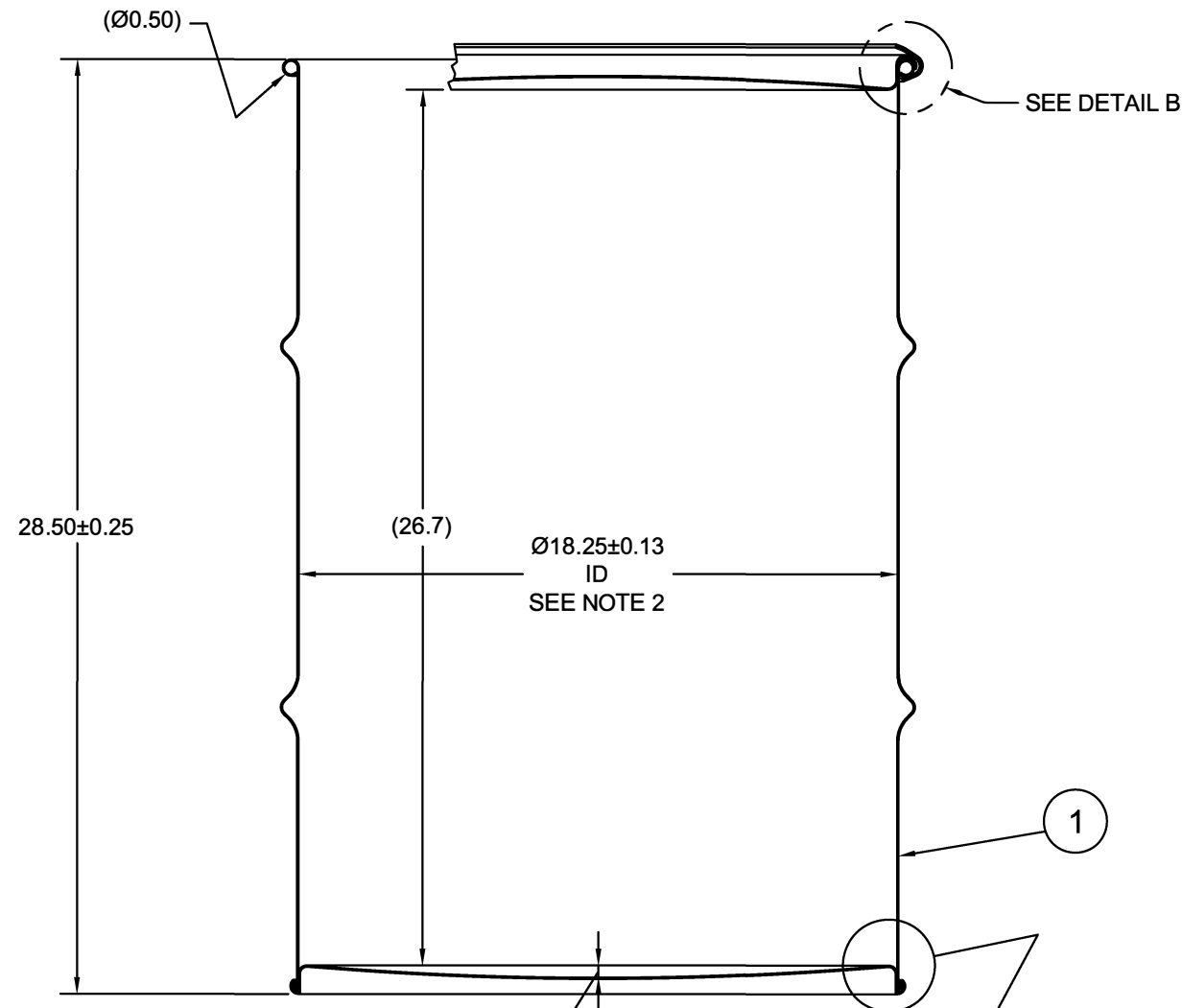
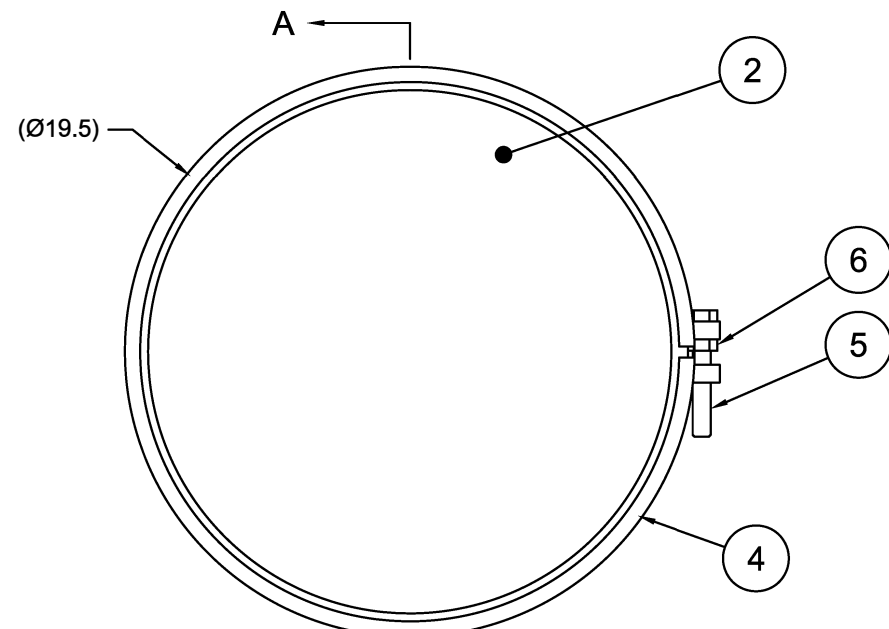

NOTES:

1. THESE DIMENSIONS REPRESENT DRUM AFTER BEING PROPERLY ASSEMBLED AND CLOSED PER CLOSING INSTRUCTIONS
2. TO DETERMINE GREATER ACCURACY OF ANY DIAMETRIC DIMENSION, MEASURING OF CIRCUMFERENCE IS REQUIRED
3. CONSTRUCTION per 49 CFR §178.504 (b)

MATERIAL:

1. DRUM BODY AND COVER CRCQ CARBON STEEL PER ASTM A1008 AND ASTM A568 OR EQUIVALENT
2. MATERIAL THICKNESS 1.2mm(0.0433 - 0.0480, 18 GAUGE)
3. GASKET MAT'L PER ASTM D1056

FINISH:

1. BODY/BOTTOM EXTERIOR PAINTED BLACK (LQ10003)
COVER EXTERIOR PAINTED WHITE (LQ10020)

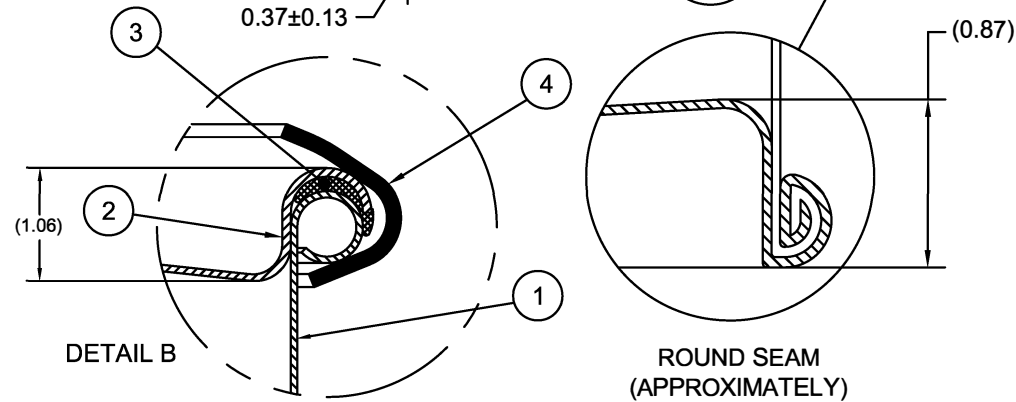

ITEM	P/N	DESCRIPTION	QTY
7		UN DURABLE LABEL	1
6	NT5800	5/8-11UNC HEX JAM NUT	1
5	BT5840	5/8-11UNC X 4in LONG HEX HEAD BOLT	1
4	RBH1812	BOLT RING 20-30G 12 GA 5/8 LUG	1
3	GE2000	GASKET EPDM IN-COVER D	1
2	P1812	COVER, Ø18.25 DRUM, CRCQ STEEL	1
1		30 GALLON DRUM BODY AND BOTTOM	1

UN NUMBER EMBOSSED ON BOTTOM OF DRUM
 ½" CHARACTERS READING:
 UN/1A2/X235/S/YR
 UN/1A2/Y1.5/150/YR
 1.2 *

(YR = YEAR OF MANUFACTURE)

TARE WEIGHT:
33 lbs

MFG BR	DRW LJT	CHK BL
	SLS	QA MD
Petersen		
FILE CREATED IN AutoCAD 2002		

UNLESS STATED OTHERWISE

(DIMENSIONS IN PARENTHESIS ARE FOR REFERENCE ONLY!!!)
 ALL DIMENSIONS ARE IN INCHES
 DO NOT SCALE DRAWING
 TOLERANCES:
 FRACTIONS ±1/4 X° ± 3°
 X.X ± 0.2
 X.XX ± 0.10
 X.XXX ± 0.030

The **CARY COMPANY** Est. 1895

DESCRIPTION
30 GALLON OPEN HEAD DRUM
1.2 - 1.2 - 1.2 CRCQ
1A2/X235/S & 1A2/Y1.5/150

REL. DATE 03-MAY-2010	PART NUM. / FILENAME CQ3005	REV A3
--------------------------	--------------------------------	-----------