

# IF YOU...



MIX IT. FILL IT. PACK IT. SHIP IT.

# WE HAVE A **PRODUCT** FOR YOU

Part #: 30BBTP

Electric Pumps

Electric PP Drum Pump for  
15-55 Gallon Drums



The  
**CARY**COMPANY  
Est. 1895

1195 W. Fullerton Ave. | Addison, IL 60101 | T: 630.629.6600 | F: 630.629.3690 |

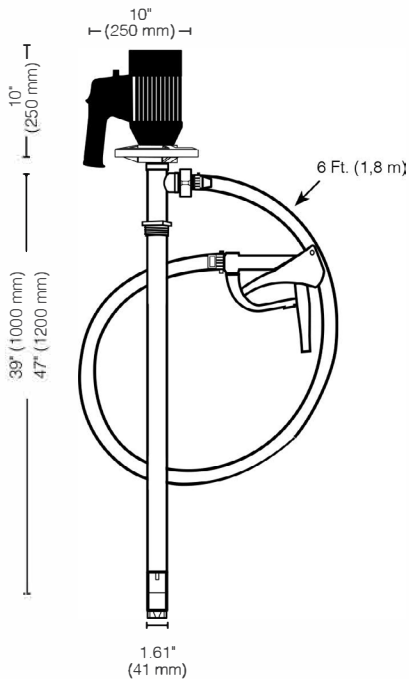

## Technical Specifications

**Package Includes:**..... Motor, Pump Tube, Hose, Storage Bracket, Barrel Adapter & Hand Nozzle

**Motor Type:**..... Open Drip Proof (IP44)

**Pump Tube Material:**.. Polypropylene, Hastelloy C-276, Carbon Graphite

**Immersion Length:**..... 39" (1000 mm) or 47" (1200 mm)

**Discharge Hose:** .....PVC, 6 ft (1,8 m), 1" (25 mm) I.D.

**Hand Nozzle Material:** .....Polypropylene, Viton

**Maximum Flow Rate:**..... 15 GPM (57 LPM) *based on water*

**Maximum Viscosity:** ..... 1500 cps (mPas)

**Maximum Temperature:** ..... 130° F (55° C)

**Shipping Weight:**..... 22 lbs. (9,97 kg)



## DRUMS

Package P/N	Motor	Volts	Pump Tube
	280P-V	110V	PP-39



**Warning: This pump is not suitable for use with Flammable/Combustible liquids.**

\*Note: When pumping viscosities over 1,000 cps, pump must be used intermittently to avoid potential premature failure and/or damage.