

IF YOU...

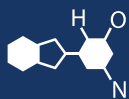

MIX IT. FILL IT. PACK IT. SHIP IT.

WE HAVE A **PRODUCT** FOR YOU

Part #: 30WB45

Continuous Thread Caps

45mm 45-400 Black Ribbed (Matte Top) Plastic Cap
w/Foam Liner (3-ply)



The
CARYCOMPANY
Est. 1895

1195 W. Fullerton Ave. | Addison, IL 60101 | T: 630.629.6600 | F: 630.629.3690 |

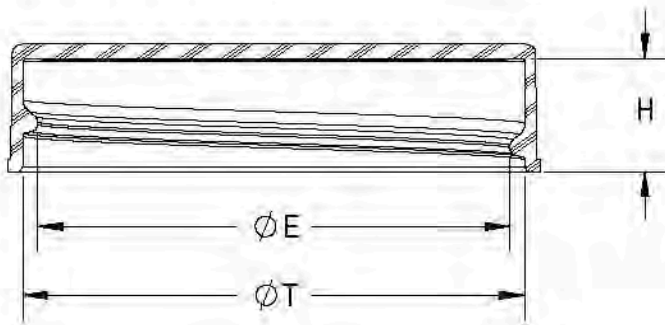
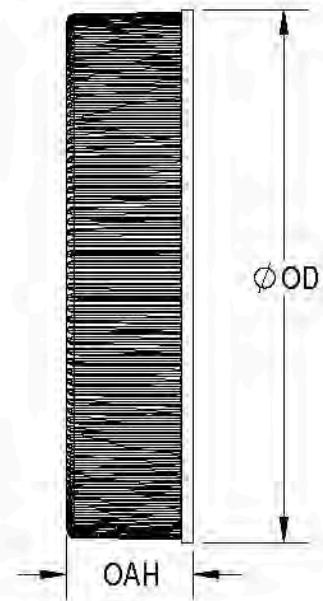
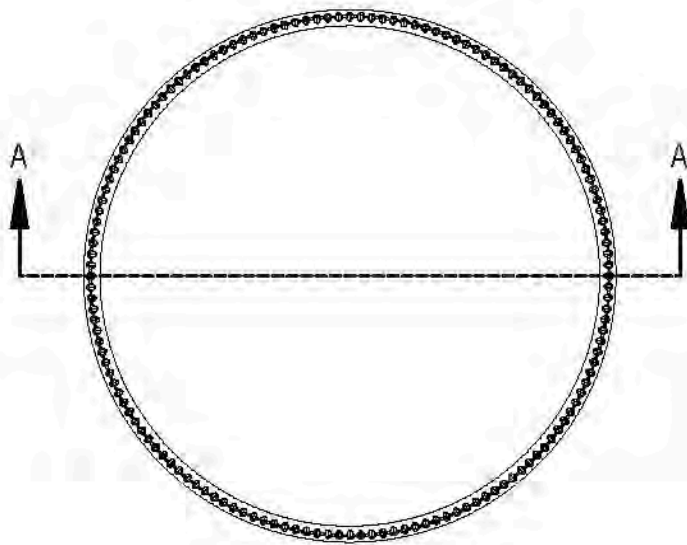

SECTION A-A

**THREAD DETAIL:
6 THREADS PER INCH, 0.167" PITCH**

REFERENCE	TOLERANCE	UNITS	DIMENSION
E	±0.010 [0.25]	in [mm]	1.656 [42.06]
T	±0.010 [0.25]	in [mm]	1.752 [44.5]
H	±0.010 [0.25]	in [mm]	0.390[9.91]
OD	±0.012 [0.30]	in [mm]	1.865 [47.37]
OAH	±0.010 [0.25]	in [mm]	0.445 [11.30]
PART WEIGHT	± 0.50	g	3.90

STATIC TORQUE RECOMMENDATION
17-27 in-lbs
THIS REQUIREMENT MAY VARY DEPENDING
UPON BOTTLE MATERIAL, NECK FINISH, AND
CAPPING EQUIPMENT

DRAWING TYPE: CUSTOMER			
REPLACES DRAWINGS: C-6010		DIMENSIONS ENCLOSED IN () INDICATE REFERENCE DIMENSIONS AND NO TOLERANCE LIMITS ARE ESTABLISHED	
TOLERANCES UNLESS OTHERWISE SPECIFIED			
DIMENSION (inches)	TOLERANCE	DIMENSION (mm)	TOLERANCE
0-0.787	±0.006	0-20	±0.152
0.788-1.181	±0.008	21-30	±0.203
1.182-2.766	±0.012	31-70	±0.305
2.757-3.937	±0.016	71-100	±0.406
3.938-5.096	±0.020	101-150	±0.508
5.097-7.874	±0.024	151-200	±0.610
7.875-9.843	±0.032	201-250	±0.813
ANGULAR TOLERANCE ± 2°			
PROPRIETARY AND CONFIDENTIAL			

The
CARY COMPANY
Est. 1895



DISTRIBUTION
CODE
D

DRAWING NAME
45-400 CT CLOSURE
RMX (Ribbed Side - Matte Top)

DRAWING NUMBER
CQA - 10302

MATERIAL
POLYPROPYLENE

MODEL NUMBER:
PM 10297 45-400 CT

DRAWN BY:	JDM	6/3/2016
ENG APPR.:	LES	12/20/2021
QA APPR.:	TEM	12/21/2021

SCALE	SHEET SIZE	SHEET	REV.NP
1:1	11 in x 8.5 in	1 of 3	00.AD

REVISIONS					
DATE	REV	NP	DESCRIPTION	ENG	DRWN
6/3/2016	00	AA	UPDATE DRAWING FORMAT, REFER TO C-5010 FOR REVISION HISTORY	JDM	JDM
12/27/2016	00	AB	CORRECTED PART WEIGHT (WAS 3.6), ±0.012 [0.30] OD TOLERANCE WAS ±0.010[0.25]	JDM	JDM
7/27/2017	00	AC	UPDATED OD TOLERANCE, T DIMENSION AND PART WEIGHT BASED ON HISTORICAL DATA, ADDED MOLD GATE LOCATION TABLE	BDG	DAS
12/27/2021	00	AD	CORRECT RIB COUNT NOTE TO MATCH PHYSICAL PARTS. UPDATE RECOMMENDED NECK FINISH "H" TOLERANCE FROM BILATERAL (+/-) TO RECOMMENDED MINIMUM	LES	LES

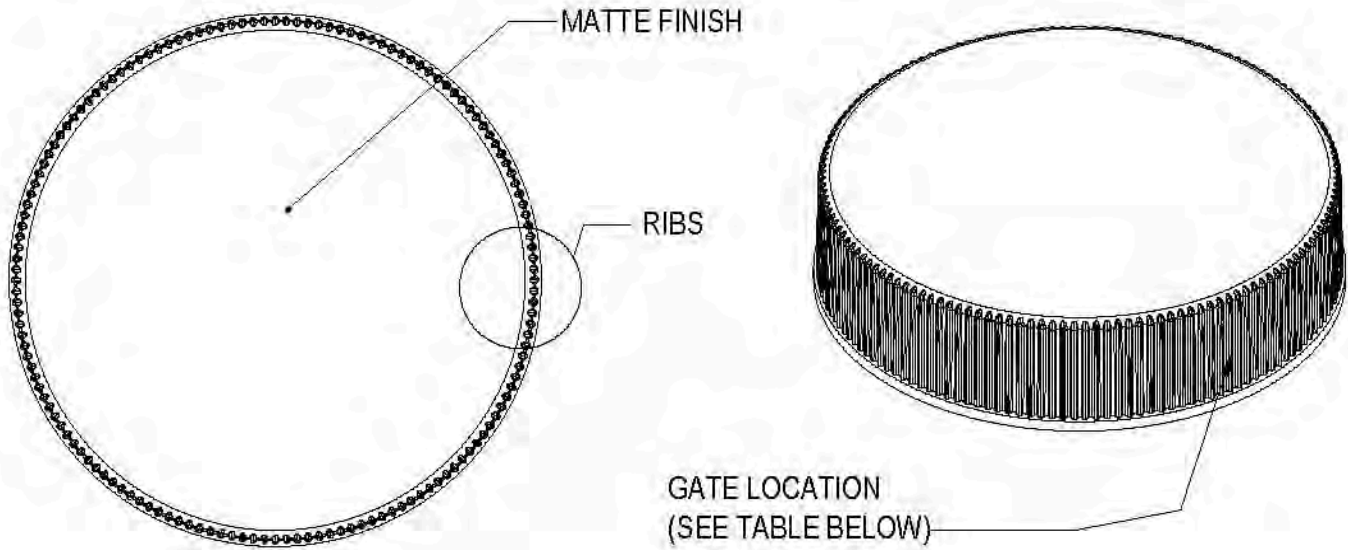

148 EQUALLY SPACED RIBS
DETAIL RIBS
SCALE 4 : 1

MOLD NUMBER	GATE LOCATION
45003	SIDE
45007	SIDE

THIS MASTER DOCUMENT IS CONTROLLED. ELECTRONICALLY PRINTED OR DOWNLOADED COPIES ARE UNCONTROLLED. DOCUMENT USERS ARE RESPONSIBLE FOR ENSURING THEY HAVE THE LATEST REVISION PRIOR TO USE.

DRAWING TYPE: CUSTOMER			
REFERENCES: 45003, 45007		DIMENSIONS ENCLOSED IN () INDICATE REFERENCE DIMENSIONS AND NO TOLERANCE LIMITS ARE ESTABLISHED	
TOLERANCES UNLESS OTHERWISE SPECIFIED			
DIMENSION (inches)	TOLERANCE	DIMENSION (mm)	TOLERANCE
0-0.787	±0.006	0-20	±0.152
0.788-1.181	±0.008	21-30	±0.203
1.182-2.766	±0.012	31-70	±0.305
2.767-3.937	±0.016	71-100	±0.406
3.938-5.096	±0.020	101-150	±0.508
5.097-7.874	±0.024	151-200	±0.610
7.875-9.843	±0.032	201-250	±0.813
ANGULAR TOLERANCE ± 2°			
PROPRIETARY AND CONFIDENTIAL			

The
CARY COMPANY
Est. 1895

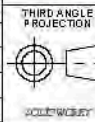

THIRD ANGLE
PROJECTION
DISTRIBUTION
CODE
D

DRAWING NAME
45-400 CT CLOSURE
RMX (Ribbed Side - Matte Top)

DRAWING NUMBER
CQA - 10302

DRAWN BY: JDM 6/3/2016

MATERIAL
POLYPROPYLENE

ENG APPR: LES 12/20/2021

MODEL NUMBER: PM 10297 45-400 CT

QA APPR: TEM 12/21/2021

SCALE	SHEET SIZE	SHEET	REVNP
1.5:1 & NOTED	8.5 X 11	2 of 3	00 AD

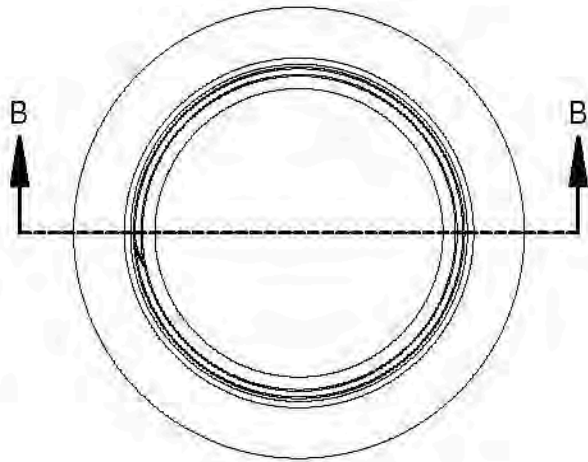

0.050" [1.27mm]
MINIMUM LAND
FOR INDUCTION SEAL

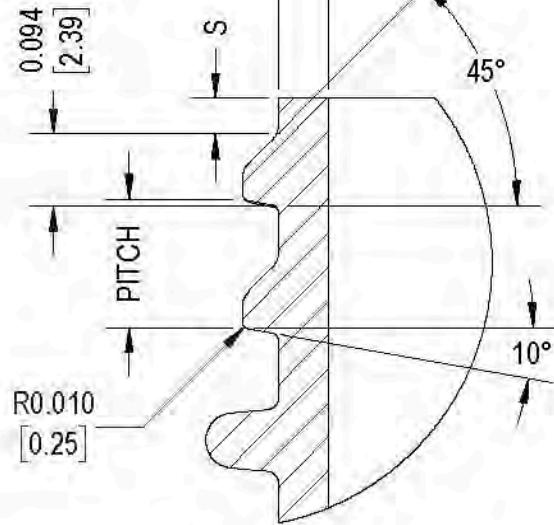

DETAIL THREAD
SCALE 4 : 1

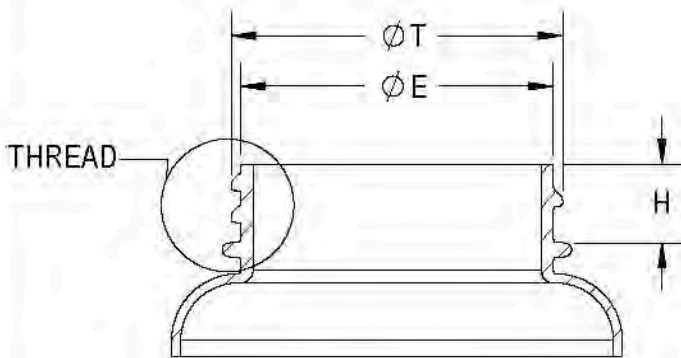

SECTION B-B
SCALE 1 : 1

REFERENCE	TOLERANCE	UNITS	DIMENSION
E	± 0.017 [0.43]	in [mm]	1.631 [41.43]
T	± 0.017 [0.43]	in [mm]	1.725 [43.82]
S	± 0.015 [0.38]	in [mm]	0.046 [1.17]
H	MINIMUM	in [mm]	0.400 [10.16]
TPI			6
PITCH		in [mm]	0.167 [4.24]

NOTE: THE NOMINAL ORIENTATION ILLUSTRATED IS BASED ON NOMINAL DIMENSIONS OF BOTH THE CLOSURE AND THE RECOMMENDED NECK FINISH FOR EXACT ORIENTATION EACH BOTTLE SHOULD BE EVALUATED ON A CASE BY CASE BASIS.

DRAWING TYPE: CUSTOMER

DIMENSIONS ENCLOSED IN () INDICATE REFERENCE DIMENSIONS AND NO TOLERANCE LIMITS ARE ESTABLISHED

TOLERANCES UNLESS OTHERWISE SPECIFIED

DIMENSION (inches)	TOLERANCE	DIMENSION (mm)	TOLERANCE
0-0.787	±0.006	0-20	±0.152
0.788-1.181	±0.008	21-30	±0.203
1.182-2.756	±0.012	31-70	±0.305
2.757-3.937	±0.016	71-100	±0.406
3.938-5.096	±0.020	101-150	±0.508
5.097-7.874	±0.024	151-200	±0.610
7.875-9.843	±0.032	201-250	±0.813

ANGULAR TOLERANCE ± 2°

PROPRIETARY AND CONFIDENTIAL

The
CARY COMPANY
Est. 1895

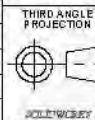

THIRD ANGLE
PROJECTION
D

DISTRIBUTION
CODE
D

DRAWING NAME

45-400 CT CLOSURE
RECOMMENDED NECK FINISH

DRAWING NUMBER

CQA - 10302

DRAWN BY

JDM

6/8/2016

MATERIAL

ENG APPR.

LES

12/20/2021

MODEL NUMBER:

QA APPR.

TEM

12/21/2021

SCALE
1:1 & NOTED

SHEET SIZE
8.5 X 11

SHEET
3 of 3

REV/NP
00.AD