

IF YOU...



MIX IT. FILL IT. PACK IT. SHIP IT.

WE HAVE A **PRODUCT** FOR YOU

Part #: 30WC2B



The
CARYCOMPANY
Est. 1895

1195 W. Fullerton Ave. | Addison, IL 60101 | T: 630.629.6600 | F: 630.629.3690 |

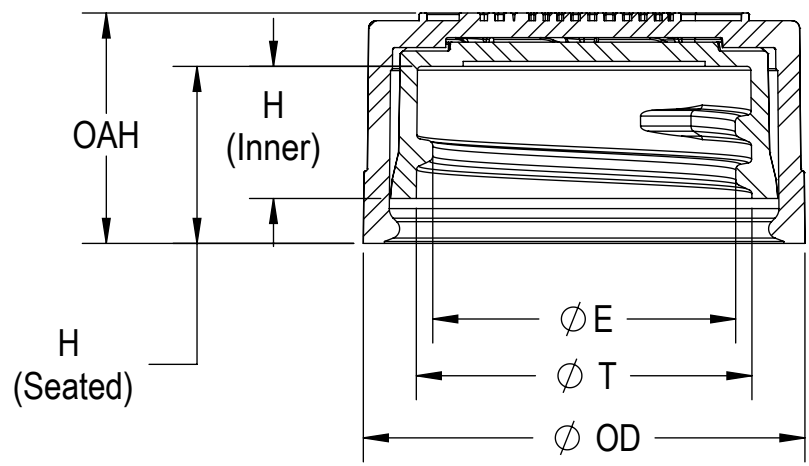
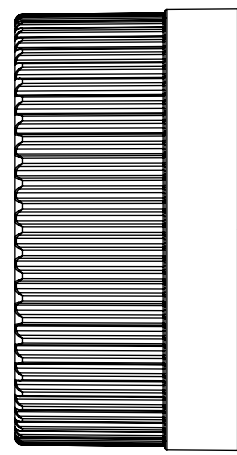
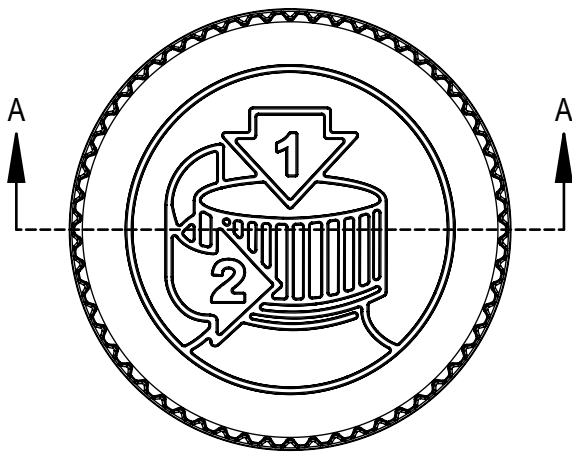

SECTION A-A

8 THREADS PER INCH, 0.125 PITCH

REFERENCE	TOLERANCE	DIMENSION	UNITS
E	±0.007 [0.18]	0.781 [19.84]	in [mm]
T	±0.007 [0.18]	0.870 [22.10]	in [mm]
H [Seated]	REFERENCE	0.461 [11.71]	in [mm]
H [INNER]	±0.007 [0.18]	0.352 [8.94]	in [mm]
OD	±0.010 [0.25]	1.130 [28.70]	in [mm]
OAH	±0.007 [0.18]	0.600 [15.24]	in [mm]
PART WEIGHT	± 0.20	3.42	g

STATIC TORQUE RECOMMENDATION
9-14 in-lbs
 THIS REQUIREMENT MAY VARY DEPENDING UPON BOTTLE MATERIAL, NECK FINISH, AND CAPPING EQUIPMENT

DRAWING TYPE : CUSTOMER

REPLACES DRAWINGS: _____
 DIMENSIONS ENCLOSED IN () INDICATE REFERENCE DIMENSIONS AND NO TOLERANCE LIMITS ARE ESTABLISHED

TOLERANCES UNLESS OTHERWISE SPECIFIED			
DIMENSION (inches)	TOLERANCE	DIMENSION (mm)	TOLERANCE
0-0.787	±0.006	0-20	±0.152
0.788-1.181	±0.008	21-30	±0.203
1.182-2.756	±0.012	31-70	±0.305
2.757-3.937	±0.016	71-100	±0.406
3.938-5.096	±0.020	101-150	±0.508
5.097-7.874	±0.024	151-200	±0.610
7.875-9.843	±0.032	201-250	±0.813

ANGULAR TOLERANCE ± 2°
 PROPRIETARY AND CONFIDENTIAL

THIS DRAWING IS PROTECTED BY COPYRIGHT AND CONTAINS INFORMATION PROPRIETARY TO THE CARY COMPANY. ANY REPRODUCTION, DISCLOSURE, OR USE OF ITS CONTENTS OR ANY PART THEREOF IS EXPRESSLY PROHIBITED EXCEPT AS OTHERWISE MAY AGREE IN WRITING

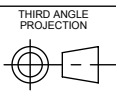

DISTRIBUTION CODE
D

DRAWING NAME
22-400 CRC ASSM PICTO LOGO

DRAWING NUMBER
CQA - 10177

DRAWN BY: DAS 6/8/2016

MATERIAL
POLYPROPYLENE

ENG APPR: BDG 6/13/2017

MODEL NUMBER: **PM 10175 22-400 CRC PDT Assem**

QA APPR: REL 6/21/2017

SCALE	SHEET SIZE	SHEET	REV NP
2:1	8.5in*11in	1 of 3	02.AC

THE CLOSURE DIMENSIONS DEPICTED ARE THOSE WHICH HAVE GENERALLY BEEN FOUND TO BE FUNCTIONAL BASED ON INDUSTRY EXPERIENCE BECAUSE OF VARIABILITY IN GLASS AND PLASTIC CONTAINER FINISHES, EACH CLOSURE/FINISH SYSTEM SHOULD BE INDIVIDUALLY EVALUATED AND TESTED TO ENSURE IT MEETS APPLICABLE PERFORMANCE CRITERIA. SEE QUALITY ASSURANCE SPECIFICATIONS FOR ADDITIONAL INFORMATION.

THE CARY COMPANY RESERVES THE RIGHT TO REVISE ANY OR ALL SPECIFICATIONS AND REQUIREMENTS.

AVAILABLE OPTIONS

DATE	REV	N/P	DESCRIPTION	ENG	DRWN
8/8/2016	01	AA	UPDATED DRAWING FORMAT	BDG	DAS
10/4/2016	02	AA	REVISED LUG HEIGHT ON OUTER. REVISION HAS SUCCESSFULLY PASSED A SENIOR RESECURE TEST.	BDG	BDG
06/13/2017	02	AB	UPDATED OD TOLERANCE TO ± 0.010 WAS ± 0.007	BDG	BDG
09/05/2017	02	AC	CORRECTED METRIC CONVERSION FOR OD	BDG	BDG

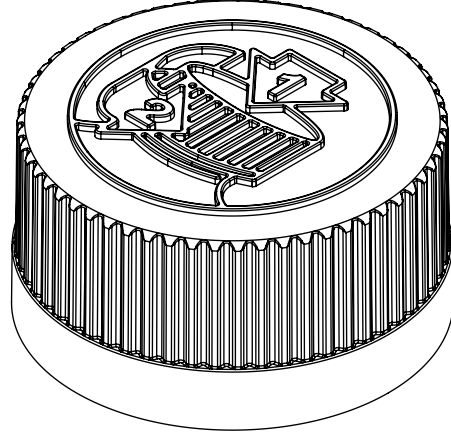
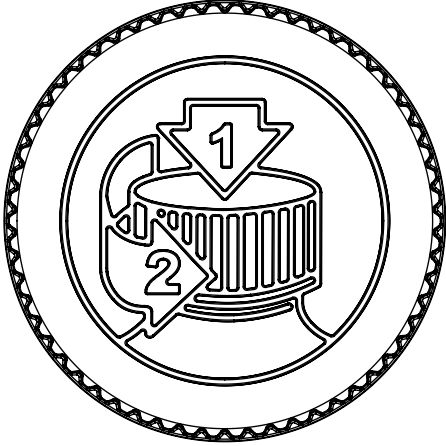

DRAWING TYPE : CUSTOMER

REFERENCES:
22002

DIMENSIONS ENCLOSED IN ()
INDICATE REFERENCE
DIMENSIONS AND NO TOLERANCE
LIMITS ARE ESTABLISHED

TOLERANCES UNLESS OTHERWISE SPECIFIED

DIMENSION (inches)	TOLERANCE	DIMENSION (mm)	TOLERANCE
0-0.787	± 0.006	0-20	± 0.152
0.788-1.181	± 0.008	21-30	± 0.203
1.182-2.756	± 0.012	31-70	± 0.305
2.757-3.937	± 0.016	71-100	± 0.406
3.938-5.096	± 0.020	101-150	± 0.508
5.097-7.874	± 0.024	151-200	± 0.610
7.875-9.843	± 0.032	201-250	± 0.813

ANGULAR TOLERANCE $\pm 2^\circ$

PROPRIETARY AND CONFIDENTIAL

THIS DRAWING IS PROTECTED BY COPYRIGHT AND CONTAINS INFORMATION PROPRIETARY TO THE CARY COMPANY. ANY REPRODUCTION, DISCLOSURE, OR USE OF ITS CONTENTS OR ANY PART THEREOF IS EXPRESSLY PROHIBITED EXCEPT AS OTHERWISE MAY AGREE IN WRITING

The
CARY COMPANY
Est. 1895

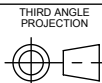

SOLIDWORKS

DISTRIBUTION
CODE
D

DRAWING NAME
**22-400 CRC ASSM
PCTO LOGO**

DRAWING NUMBER
CQA - 10177

DRAWN BY. DAS 6/8/2016 MATERIAL POLYPROPYLENE

ENG APPR. BDG 6/13/2017 MODEL NUMBER: PM 10175 22-400 CRC PDT Assem

QA APPR. REL 6/21/2017 SCALE 2:1 SHEET SIZE 8.5 X 11 SHEET 2 of 3 REV.NP 02.AC

THE CLOSURE DIMENSIONS DEPICTED ARE THOSE WHICH HAVE GENERALLY BEEN FOUND TO BE FUNCTIONAL BASED ON INDUSTRY EXPERIENCE BECAUSE OF VARIABILITY IN GLASS AND PLASTIC CONTAINER FINISHES. EACH CLOSURE/FINISH SYSTEM SHOULD BE INDIVIDUALLY EVALUATED AND TESTED TO ENSURE IT MEETS APPLICABLE PERFORMANCE CRITERIA. SEE QUALITY ASSURANCE SPECIFICATIONS FOR ADDITIONAL INFORMATION.

THE CARY COMPANY RESERVES THE RIGHT TO REVISE ANY OR ALL SPECIFICATIONS AND REQUIREMENTS.

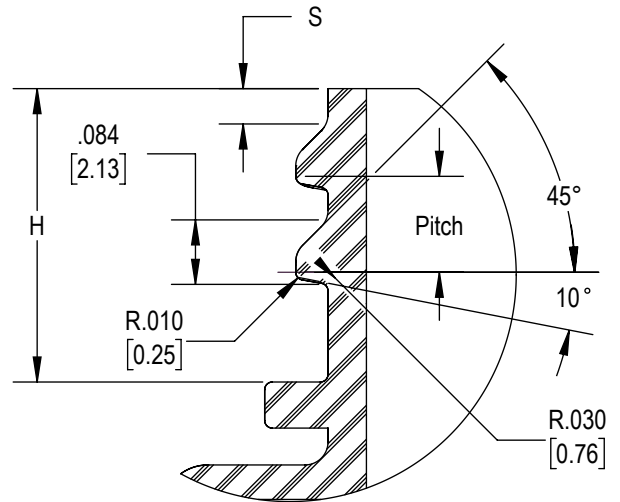
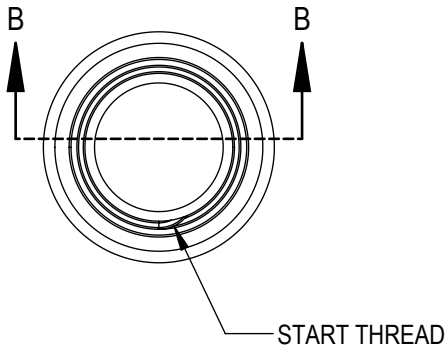

DETAIL D
SCALE 4 : 1

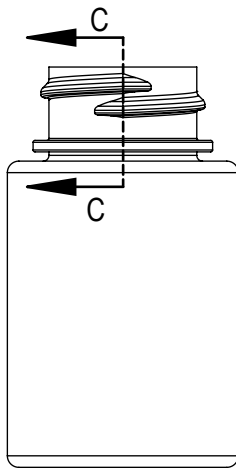
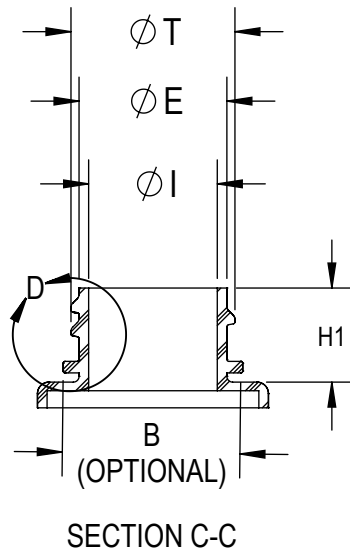

REFERENCE	TOLERANCE	UNITS	DIMENSION
E	$\pm 0.008[0.20]$	in [mm]	0.770[19.56]
T	$\pm 0.008[0.20]$	in [mm]	0.854[21.69]
I	MINIMUM	in [mm]	0.483[12.27]
S	$\pm 0.015[0.38]$	in [mm]	0.037[0.94]
H	MINIMUM	in [mm]	0.370[9.40]
H1	MINIMUM	in [mm]	0.490[12.45]
B	MAXIMUM	in [mm]	0.935[23.75]
TPI			8
PITCH		in [mm]	0.125[3.18]

NOTE: THE NOMINAL ORIENTATION ILLUSTRATED IS BASED ON NOMINAL DIMENSIONS OF BOTH THE CLOSURE AND THE RECOMMENDED NECK FINISH. FOR EXACT ORIENTATION EACH BOTTLE SHOULD BE EVALUATED ON A CASE BY CASE BASIS.

DRAWING TYPE : CUSTOMER

DIMENSIONS ENCLOSED IN () INDICATE REFERENCE DIMENSIONS AND NO TOLERANCE LIMITS ARE ESTABLISHED

TOLERANCES UNLESS OTHERWISE SPECIFIED

DIMENSION (inches)	TOLERANCE	DIMENSION (mm)	TOLERANCE
0-0.787	± 0.006	0-20	± 0.152
0.788-1.181	± 0.008	21-30	± 0.203
1.182-2.756	± 0.012	31-70	± 0.305
2.757-3.937	± 0.016	71-100	± 0.406
3.938-5.096	± 0.020	101-150	± 0.508
5.097-7.874	± 0.024	151-200	± 0.610
7.875-9.843	± 0.032	201-250	± 0.813

ANGULAR TOLERANCE $\pm 2^\circ$

PROPRIETARY AND CONFIDENTIAL

THIS DRAWING IS PROTECTED BY COPYRIGHT AND CONTAINS INFORMATION PROPRIETARY TO THE CARY COMPANY. ANY REPRODUCTION, DISCLOSURE, OR USE OF ITS CONTENTS OR ANY PART THEREOF IS EXPRESSLY PROHIBITED EXCEPT AS OTHERWISE MAY AGREE IN WRITING

The
CARY COMPANY
Est. 1895

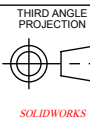

DISTRIBUTION CODE
D

DRAWING NAME
22-400 CRC ASSM PICTO LOGO
DRAWING NUMBER
CQA - 10177

DRAWN BY: DAS 6/8/2016

MATERIAL
POLYPROPYLENE

ENG APPR: BDG 6/13/2017

MODEL NUMBER
PM 10175 22-400 CRC PDT Assem

QA APPR: REL 6/21/2017

SCALE: 1:1
SHEET SIZE: 8.5in*11in
SHEET: 3 of 3
REV/NIP: 02.AA

THE CLOSURE DIMENSIONS DEPICTED ARE THOSE WHICH HAVE GENERALLY BEEN FOUND TO BE FUNCTIONAL BASED ON INDUSTRY EXPERIENCE BECAUSE OF VARIABILITY IN GLASS AND PLASTIC CONTAINER FINISHES. EACH CLOSURE/FINISH SYSTEM SHOULD BE INDIVIDUALLY EVALUATED AND TESTED TO ENSURE IT MEETS APPLICABLE PERFORMANCE CRITERIA. SEE QUALITY ASSURANCE SPECIFICATIONS FOR ADDITIONAL INFORMATION.

THE CARY COMPANY RESERVES THE RIGHT TO REVISE ANY OR ALL SPECIFICATIONS AND REQUIREMENTS.