

IF YOU...

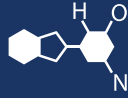

MIX IT. FILL IT. PACK IT. SHIP IT.

WE HAVE A **PRODUCT** FOR YOU

Part # 30WEZP

Industrial Pumps

5 Gallon Plastic Pail Pump



The
CARYCOMPANY
Est. 1895

TECHNICAL SPECIFICATION SHEET

<u>Product Reference</u>	Drum Pump NX 25 (imperial)
Customer Reference:	tba
Drawing:	(see over)
Dose:	6 fl oz. approx (full cycle)
Closure:	2" Trisure (others available)
No. of strokes to discharge:	6-7
Discharge pressure:	Low pressure – typical 6/8 lbs. (subject to liquid rheology)
Colour:	white
Dip tube**:	fixed

General Comments:

Low pressure drum pump – suitable for most large drums approx 5 gallon (25 litre) capacity

Anti drip nozzle

Various attachment options

High viscosity liquid dispense option

General chemical compatibility - good

Do not use to dispense petroleum products

NX25 Drum Pump (imperial)

NX25

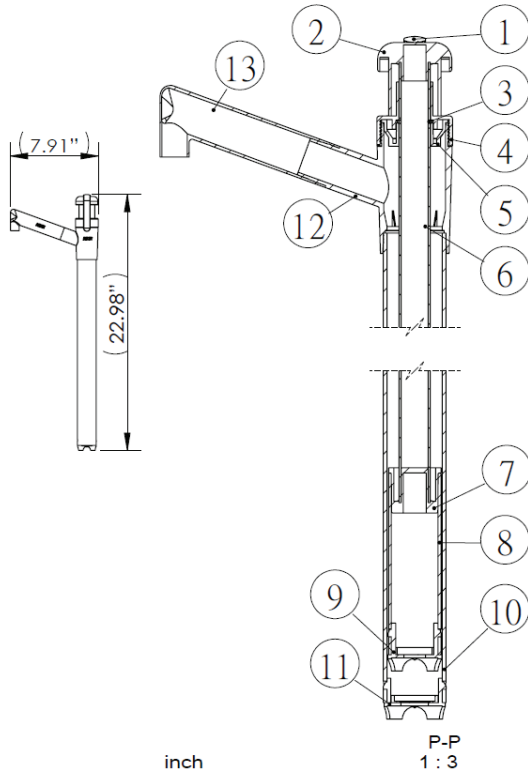

inch

NO	Component	Material
1	SAFETY STRAP	PP
2	ACTUATOR	PP
3	O-Ring	Viton
4	MAIN COLLAR	PP
5	PLUNGER COLLAR SEAL	PP
6	TOP EXTRUSION	PP
7	PLUNGER EXTRUSION CONNECTOR	PP
8	EXTRUSION	PP
9	PLUNGER FLAP VALVE	PP
10	BODY TUBE	PP
11	FOOT FLAP VALVE	PP
12	BODY	PP
13	LONG OUTLET	PP
14	Fitting Options	

