

IF YOU...

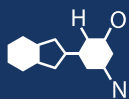

MIX IT. FILL IT. PACK IT. SHIP IT.

WE HAVE A **PRODUCT** FOR YOU

Part #: 30WG1W

Plastic Spray Bottles

10 oz. White PET Plastic Flairosol®
Spray Bottle, Bayonet Neck



The
CARYCOMPANY
Est. 1895

1195 W. Fullerton Ave. | Addison, IL 60101 | T: 630.629.6600 | F: 630.629.3690 |

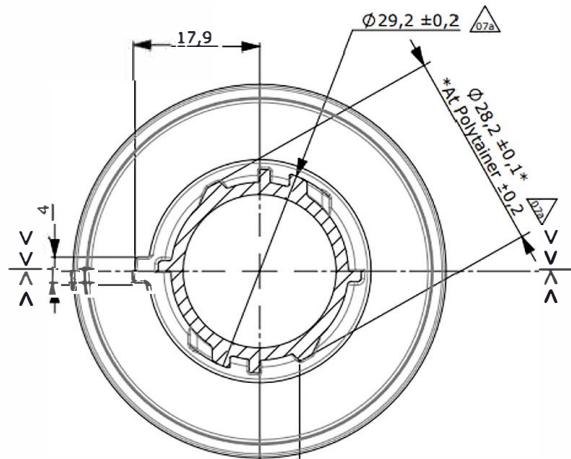

SECTION B-B
SCALE 2 : 1

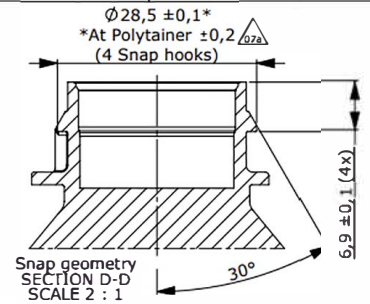
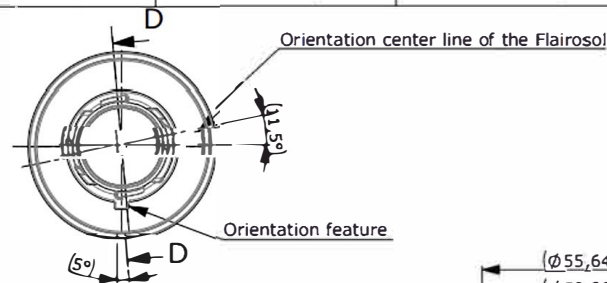

Snap geometry
SECTION D-D
SCALE 2 : 1

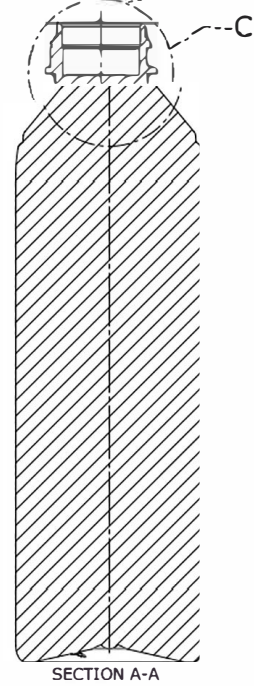
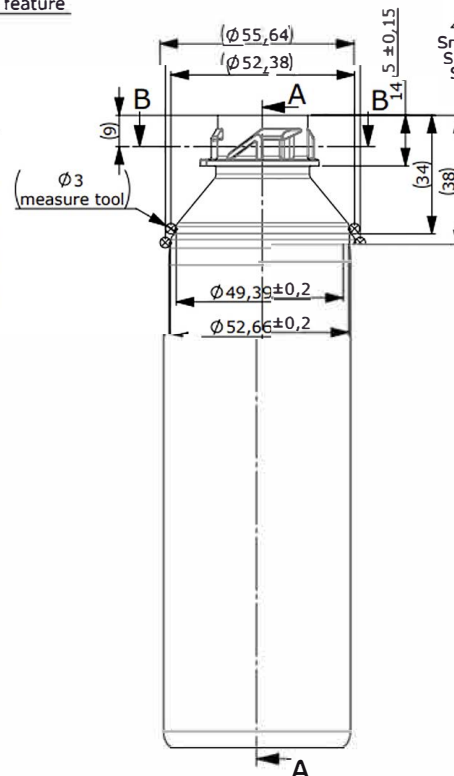
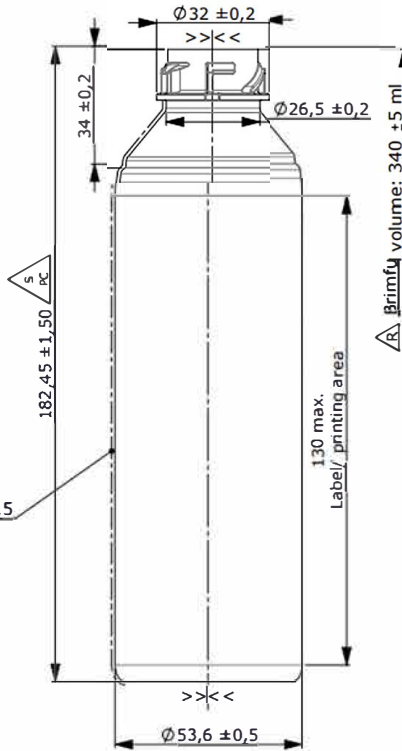

SECTION A-A

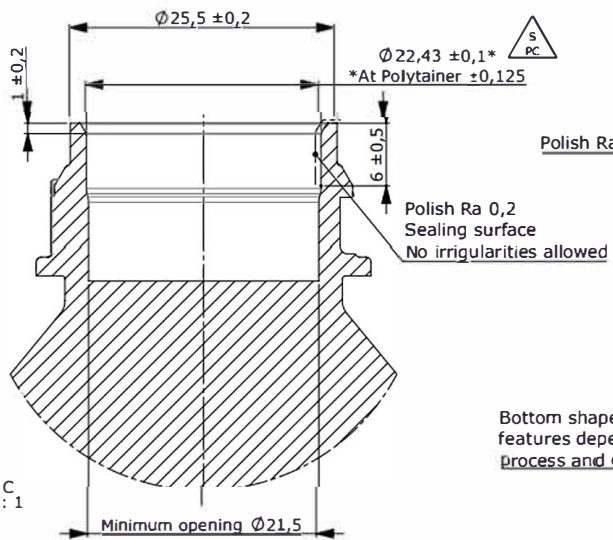

DETAIL C
SCALE 3 : 1

Bottom shape and orientation
features depending of blowing
process and equipment

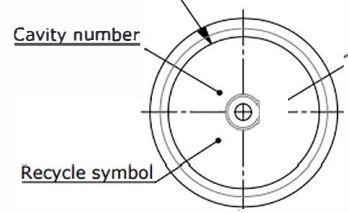

- Note:
- 1) Geometry of 3D model is leading
 - 2) Not mentioned Surface structure: Ra 1.0 Max.
 - 3) Bottle neck geometry: SNAP NON LOCK
 - 4) Bottle is made for production in America

RELEASED

$\frac{S}{PC}$ = Measure in process
 $\frac{A}{PC}$ = Measure at runrelease
 Measure all at mould release

07a	Change tolerances and add remark with Polytainer tolerance	16 Feb 2021	LVDH
07	Change inner seal diameter back to 22,43 and add remark tolerance Polytainer +/- 0,125	11 Feb 2021	LVDH
06	Change seal diameter + Update shoulder dimensions + update brimful volume + increase tolerance snap diameter + add surface structure + update drawing	09 Feb 2021	LVDH
05	Change snap diameter back to 28,5 (same as Rev. 03)	05 Feb 2021	LVDH
REV.	DESCRIPTION	DATE	INITIALS
MOLD TYPE	Production Mold	SCALE	AM.PROJ. SIZE
MATERIAL	PET	1:1	A2
VOLUME			
MASS		DRAWN	LVDH
COLOR		DATE	22 Jun 2020
ADDITIVE			
PART NUMBER	01064		
NOT SPECIFIED TOLERANCE	± 0.1 ± 1°		
DIMENSIONS	ANGLE		
PART DESCRIPTION		300 ml - 10 oz. PET Bottle Cylindrical	