

IF YOU...

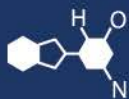

MIX IT. FILL IT. PACK IT. SHIP IT.

WE HAVE A **PRODUCT** FOR YOU

Part #: 30WHP2



The
CARYCOMPANY
Est. 1895

1195 W. Fullerton Ave. | Addison, IL 60101 | T: 630.629.6600 | F: 630.629.3690 |

SCOOPS

30WHP2



Specifications:

TYPE Scoop
VOLUME 73 cc
HANDLE Medium
DESIGN Round
MATERIAL PP

PACKAGING & FREIGHT INFORMATION

PACK TYPE	PCS/CTN	CTNS/PALT	PCS/PALT	CTN WT*	PALT WT*	FRT CLASS
Bulk	400	24	9,600	10	290	250
CARTON DIMENSIONS: 19 x 15 x 18			PALLET DIMENSIONS: 40 x 48 x 80			

*Approximate

MARKETS

Nutritional Powders, Powdered Drinks, Baby Formulas, Household Chemical; Cleaning Products; Pet Products; Plant Food & Fertilizers

SCOOP BENEFITS

- Customization options available
- Popular for nutritional powders

OPTIONS

Available in natural, white, black and colors.
Custom logo engraving available.

SCOOPS

30WHP2

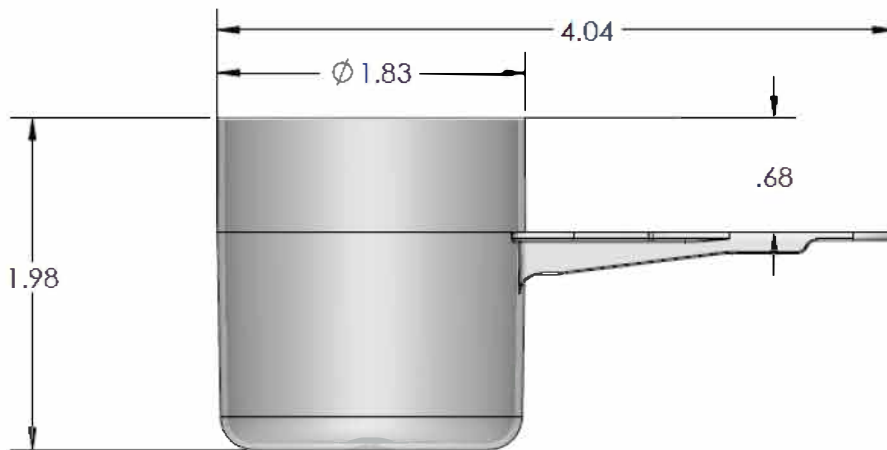
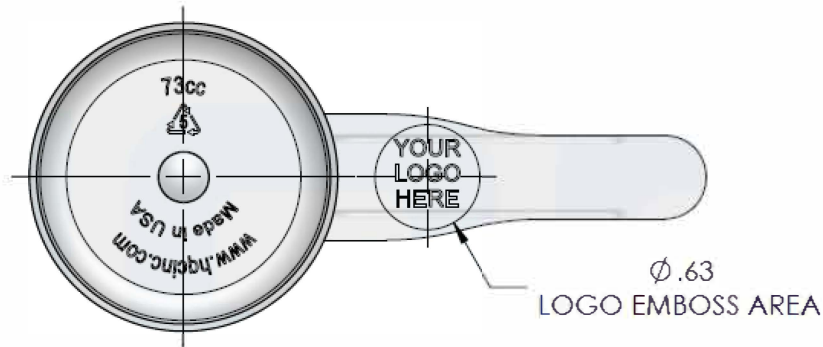
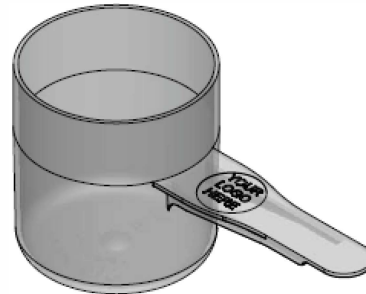

NOTES: (UNLESS OTHERWISE SPECIFIED)
 1. ALL DIMENSIONS ARE IN INCHES.
 2. SEE CHART FOR DIMENSIONAL TOLERANCE.

-		00.00.00		-		--	
REV	DATE	DESCRIPTION				BY	
TOLERANCE	PITCH/TPI	NA	/ 0	TURN	x	MAT'L	PP
.X	±0.1	DRAWN	HQC	DATE	12.30.14	SCALE	0 : 1
.XX	±0.02	30WHP2					REV
.XXX	±0.010						