

IF YOU...

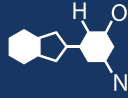

MIX IT. FILL IT. PACK IT. SHIP IT.

WE HAVE A **PRODUCT** FOR YOU

Part #: 30WN1B

Hybrid Paint Cans

1 Gallon Black Hybrid
Paint Can w/Ears



The
CARYCOMPANY
Est. 1895

1195 W. Fullerton Ave. | Addison, IL 60101 | T: 630.629.6600 | F: 630.629.3690 |

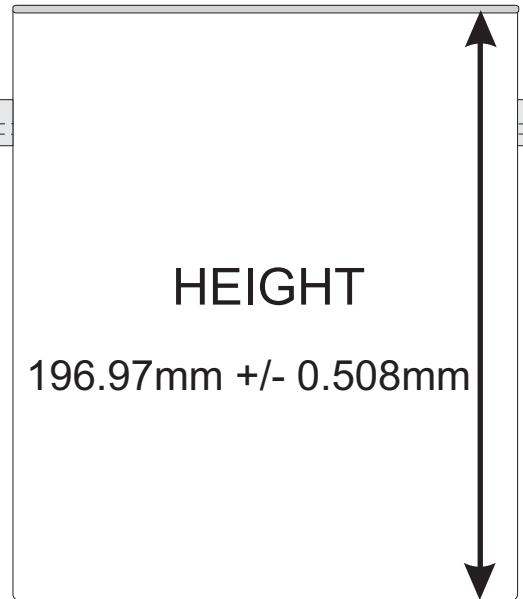
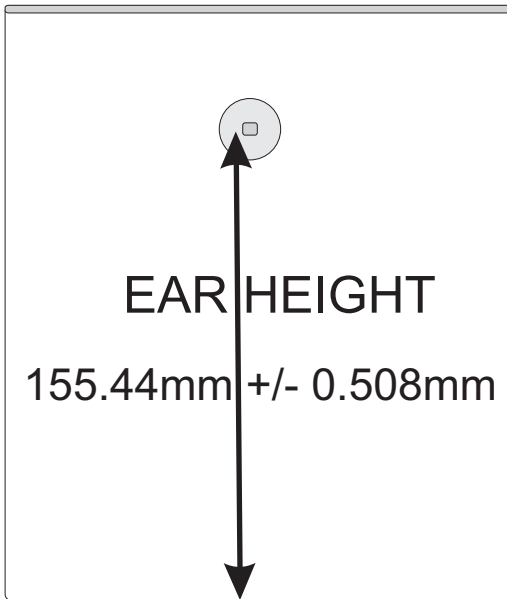
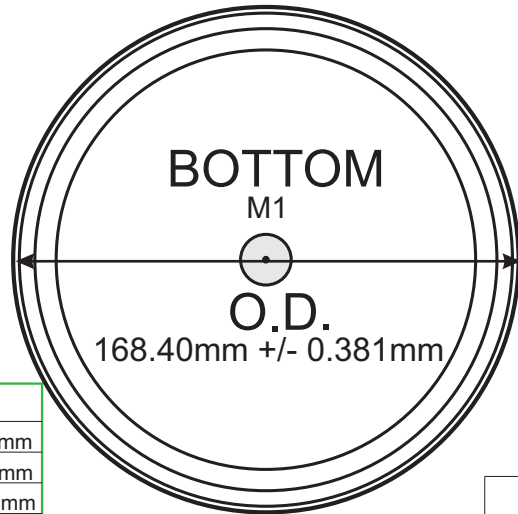
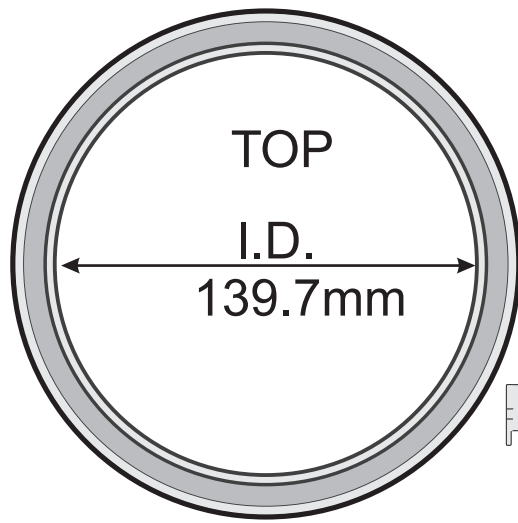

PP SPECIFICATIONS

HEIGHT OF CAN:	196.97mm +/- 0.508mm
EAR HEIGHT:	155.44mm +/- 0.508mm
NORCAN MAX. HEIGHT WITH RING & PLUG:	198.24mm
O. D. AT CENTER OF CAN:	168.40mm +/- 0.381mm
WALL THICKNESS:	1.651mm +/- .076mm
LABEL HEIGHT AVAILABLE:	189.23mm
NORCAN WEIGHT WITH RING:	230 +/- 15 GR.
NORCAN WEIGHT WITH RING & PLUG:	290 +/- 15 GR.
NORCAN BODY MATERIAL:	Polypropylene

CONTRACT No.			
DW.- JOE SCHRICK	01/29/10		
		TITLE:	
		1 GAL. PP NORCAN	
SIZE	PART NO.	DW21.6 PP NORCAN	
SCALE 1:2	FILE NO.	SHEET	

Label Approx. Dim.
And Layout
With Approx. 12.7mm Over Lap
539.75mm

