

# IF YOU...

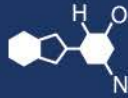

MIX IT. FILL IT. PACK IT. SHIP IT.

# WE HAVE A **PRODUCT** FOR YOU

Part #: 30WP21

---

---



---

The  
**CARY**COMPANY  
Est. 1895

1195 W. Fullerton Ave. | Addison, IL 60101 | T: 630.629.6600 | F: 630.629.3690 |

K

3		4	
MARK	REVISER	DESCRIPTN	DATE

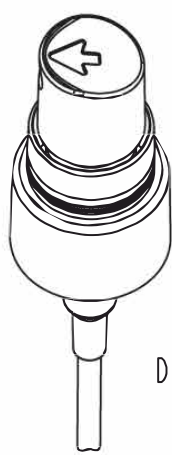
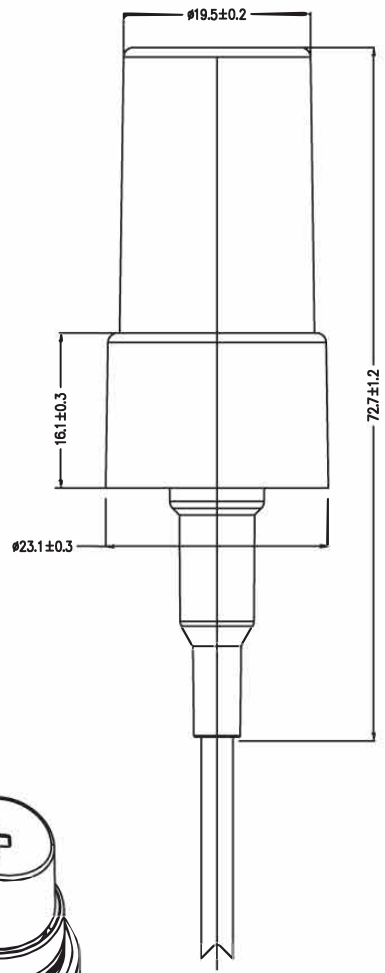
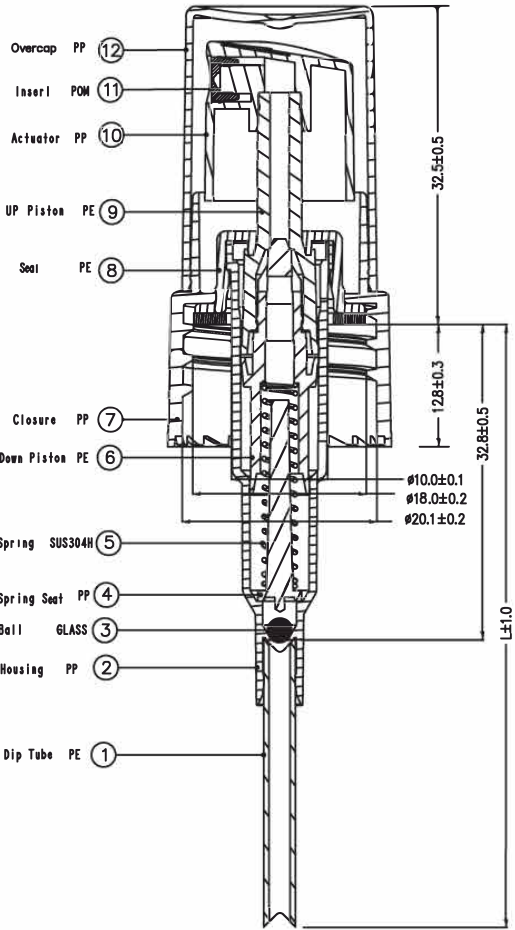

Discharge Rate: 0.20 ± 0.02 ml/T

Section A-A

F	TOLERANCE			○	DRAFTER:	UNIT: mm	The <b>CARY COMPANY</b> <small>Est. 1895</small>		
	0mm-15mm	±0.05	±0.10	±0.50		CHECKED:	MODEL NAME:	TITLE: 30WP21 Black Assembly	
	15mm-30mm	±0.05	±0.15	±1.00	SENSOR:	SCALE:	VISUAL ANGLE	Q'TY:	REV:
	30mm-50mm	±0.10	±0.20	±1.50			⊕	1/1	A0
	50mm-99mm	±0.15	±0.30	±2.00	APPROVED:	PART NO:	FILE NO:		
	ABOVE 99mm	±0.20	±0.40	±2.50			D-		
	CENTER	±0.10	±0.50	±1.00					
	ANGLER	±0.25°	±0.50°	±2.00°					