

IF YOU...



MIX IT. FILL IT. PACK IT. SHIP IT.

WE HAVE A PRODUCT FOR YOU

Part #: 30WPB6



The
CARYCOMPANY
Est. 1895

1195 W. Fullerton Ave. | Addison, IL 60101 | T: 630.629.6600 | F: 630.629.3690 |

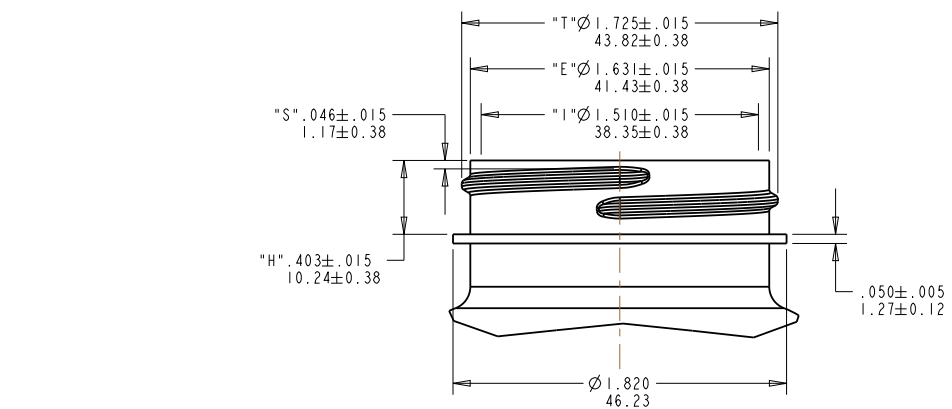
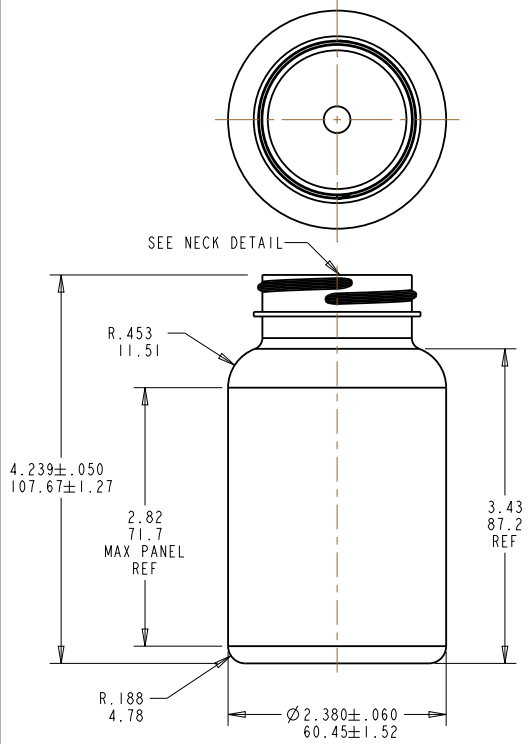

NECK DETAIL:
SCALE 2:1

FINISH SPECIFICATIONS:
1. FINISH: L45SP400 DESIGN
2. NO. OF TURNS: 1 FULL TURN
3. THREADS PER INCH: 6
4. THREAD START: 90° FROM P.L. (AS SHOWN)

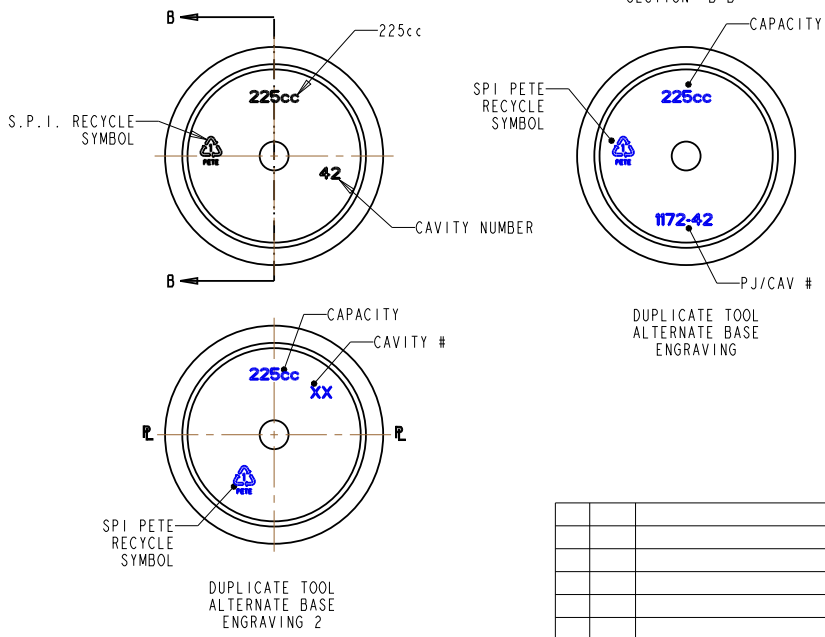
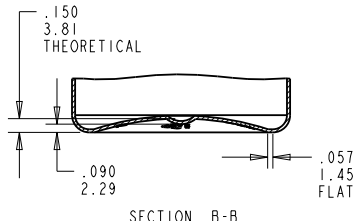

NOTES:
1. CRITICAL DIMENSIONS ARE SHOWN WITH TOLERANCES.
CRITICAL DIMENSION TO BE USED FOR QC PURPOSES.
2. ALL OTHER DIMENSIONS TO BE USED FOR REFERENCE ONLY.

The **CARY COMPANY**
Est. 1895

MINIMUM WALL THICKNESS = .016 [0,4] AT LABEL MIDPOINT

REV	ECR	DESCRIPTION	BY	DATE	REV	ECR	DESCRIPTION	BY	DATE
					H	199	Add duplicate tool base engraving; min. Update listic block. "1" and "129" min.	RAB	Jun-17-19
					G	194	Add duplicate tool base engraving.	RAB	Oct-30-18
					F		Add duplicate tool base engraving.	SCT	Jul-19-13
					E		Weight tol (ca2).	SCT	Jan-05-12
					D		Weight tol (ca1).	SCT	Jan-05-12
					C		Add min wall note.	SCT	Oct-17-11
					B		Add OFC @ 37g.	SCT	Jul-27-10
					B		Added metric dimensions.	SCT	May-04-10
					J	205	37g WAS 250cc & 28g WAS 242cc.	JAZ	Oct-25-19

No	WEIGHT (g)	OVERFLOW (cc)	MIN WALL (in)	NOTES
02	37.0 ± 3.0	242 ± 7	.012	
01	28.0 ± 3.0	250 ± 7	.012	

TITLE
225 cc STRAIGHT SIDED PACKER

TOLERANCES: UNLESS OTHERWISE SPECIFIED	DRAWN BY: SCT	NECK: L45SP400	WEIGHT (g): SEE TABLE
DECIMALS: .XX .XXX .XXXX	DATE: Feb-14-05	MIN WALL (in): SEE TABLE	OVERFLOW (cc): SEE TABLE
FRACTIONS: * ANGLES *	SCALE: 1:1	CUSTOMER: STOCK	3D FILE No: 225PM1TB45L400
SEE NOTE 1	SHEET: 1 of 1	MATERIAL: PET	DRAWING No: 225PM1TB45L400
	NPD No:		REV: J