

# IF YOU...



MIX IT. FILL IT. PACK IT. SHIP IT.

# WE HAVE A PRODUCT FOR YOU

Part #: 30WPB8

---

---



---

The  
**CARY**COMPANY  
Est. 1895

1195 W. Fullerton Ave. | Addison, IL 60101 | T: 630.629.6600 | F: 630.629.3690 |

REV	ECN	DESCRIPTION	BY	DATE
F	-	ADD STACK PACK TO HEAVY GRAM	SJ	09-OCT-01
G	-	DOC CHANGE ONLY, PROD CONFORMS	SCT	19-NOV-01
H	-	ADDED METRIC DIMENSIONS	SCT	12-MAY-10
I	-	N/A		
J	-	ADD ALT CONFIG	SCT	4-NOV-10
K	-	28g CHANGED TO 33.5g	RAB	06-FEB-13
L	-	WT TOL (±1)	SCT	13-NOV-13
M	-	REMOVE 33.5g WT	RAB	23-SEP-15
N	-	ADDED NECK FINISH NOTE, TOLERANCE NOTE & UPDATED DWG.	JAZ	06-MAY-19

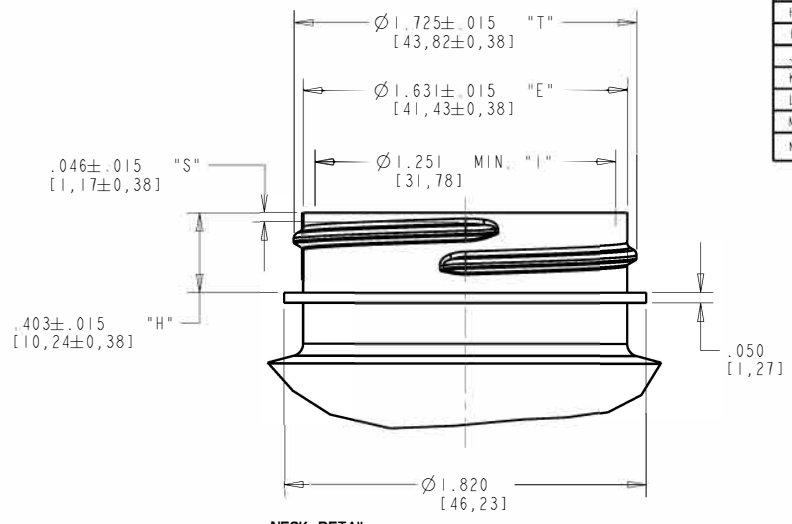
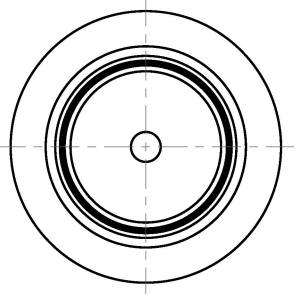

**NECK DETAIL**  
SCALE: 2:1

**FINISH SPECIFICATIONS:**  
1. FINISH: L45-400  
2. NO. OF TURNS: 1 FULL TURN  
3. THREADS PER INCH: 6  
4. THREAD START: 90° FROM P.L. (AS SHOWN)

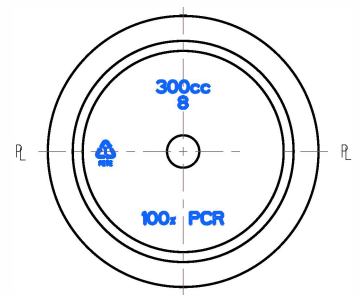
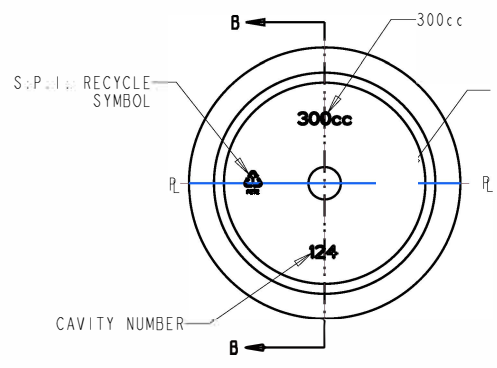
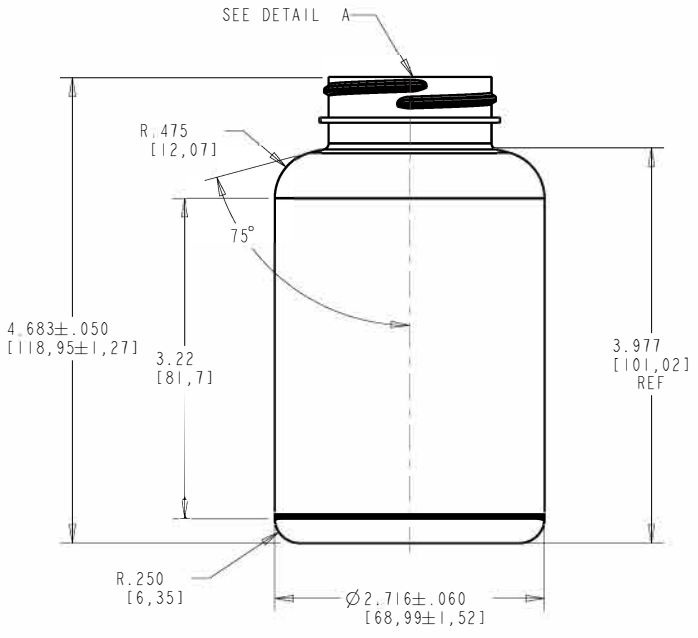
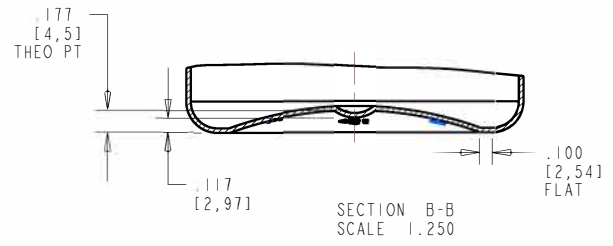

ALTERNATE BOTTOM PLUG CONFIG.

- NOTES:**  
1. CRITICAL DIMENSIONS ARE SHOWN WITH TOLERANCES. CRITICAL DIMENSION TO BE USED FOR QC PURPOSES.  
2. ALL OTHER DIMENSIONS TO BE USED FOR REFERENCE ONLY.

Specification General:	Min. Thk (in)	Weight (g)	Overflow (mL)	The CARY COMPANY Est. 1895		
All measurements are in inches, [mm]	.012 [0.3]	37.0 ± 3.0	368.0 ± 9.0	Scale: NPD #:	Drawn By:	Date:
Base engraving is subject to change location & size				1.000	1/1	SCT Jul-25-00
Tolerance where not shown	NECK FINISH:	L45-400		300cc STRAIGHT SIDED		DwaRev: N
Decimal ±0.05 [1.27] Angular ±1°	MATERIAL:	PET		Approved By:	Drawing Number:	
				SJ	300PSIXX45L400	