

IF YOU...

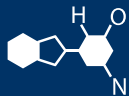

MIX IT. FILL IT. PACK IT. SHIP IT.

WE HAVE A **PRODUCT** FOR YOU

Part #: 56W5WT

Plastic Tight Head Square & Rectangular Containers

**5 Gallon (18.9L) White Plastic Tight Head Container,
70mm (6TPI), Closed Vent**



The
CARYCOMPANY
Est. 1895

1195 W. Fullerton Ave. | Addison, IL 60101 | T: 630.629.6600 | F: 630.629.3690 | TheCaryCompany.com

5.0 Gallon Rectangular Tight Head with Swing Handle

Product Uses

Liquid Products

Product Codes

Container: **RTH Series (HO)**

Description: 5.0G Rectangular Tighthead

Features

UN Rating: 3H1/Y1.8/100
 Nominal capacity: 5.0 USG / 18.9L
 Maximum capacity: 5.4 USG / 20.4 L
 Tare weights: 2.71 lbs / 1.23 kgs

Colors

Standard: White, Black, Blue and Natural
 Custom: Available at manufacturer's discretion

Decorating Options

Maximum Label Area:
 Perimeter: 38-1/4" x 8-3/16" H
 See Salesperson for Options

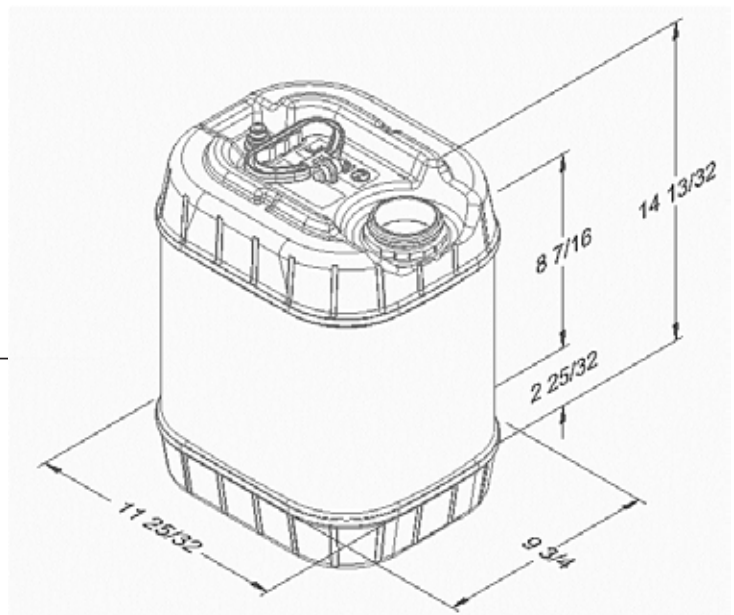

Shipping Data

Qty. per floor spot:	112
Gross Weight (lbs./kgs)*:	352 / 159
Length (in./cm.):	48 / 121
Width (in./cm.):	35.3 / 90
Height (in./cm.):	103.5/262.9

Estimated truckload quantity of 3,360 containers**

Containers

Filled Containers

Refer to BWAY document # ETS-CD-1002
 for storage and shipping recommendations.

Notes: *Weight does not include pallet / packaging
 **Truckload quantity based on 53' trailer

Materials

FDA approved materials
 Resin: Body: High-Density Polyethylene (HDPE)
 Handle/Pin: High-Density Polyethylene (HDPE)

Optional Carrying Handle

Swing Handle with Pin