

## 5.0 Gallon Square Tight Head with Integrated Handle

### Product Uses

Liquid Products

### Product Codes

Square Tight Head: **STH Series**

Multiple Neck Finishes and Vent Options

### Features

UN Rating: 3H1/Y1.8/100

Nominal capacity: 5.00 USG / 18.93 L

Maximum capacity: 5.35 USG / 20.25 L

### Colors

Standard: White, Black, Blue and Natural

Custom: Available at manufacturer's discretion

### Decorating Options

Maximum Print Area:

Perimeter = 38-1/4" W X 8"H

Containers can be decorated; See Salesperson for Options

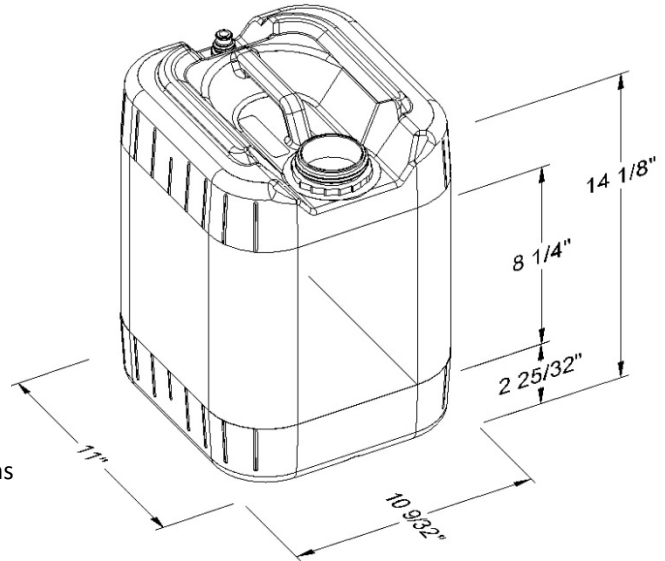

### Shipping Data:

Qty. per floor spot\*:

### Containers

112

Gross Weight (lbs/kgs.)\*\*:

296 / 135

Length (in./cm.):

44 / 112

Width (in./cm.):

33 / 84

Height (in./cm.):

102 / 260

Approximate truckload quantity of 3360 pails and covers\*\*\*

### Filled Containers

Refer to document #ETS-CD-1002 for storage and shipping recommendations.

### Notes:

\*Quantity can vary based on customer request

\*\*Weight does not include pallet/packaging

\*\*\*Based on 53' trailer and standard pallet quantities

### Materials

FDA approved materials

Resin: HDPE

MSDS Sheets and Technical Bulletin available upon request

**Handle** – Integrated into Body