

IF YOU...

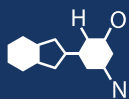

MIX IT. FILL IT. PACK IT. SHIP IT.

WE HAVE A **PRODUCT** FOR YOU

Part #: 56WW29

Round Plastic Pails

2.9 Gallon White Plastic Pail (65 mil)
(P8 Series)



The
CARYCOMPANY
Est. 1895

1195 W. Fullerton Ave. | Addison, IL 60101 | T: 630.629.6600 | F: 630.629.3690 |

2.9-Gallon Round Container with C4 Cover

Multiple Uses

Dry Products

Product Codes

Container: **C297**

Description: 2.9-gallon round can

Cover: **C4D0**

Description: Round, dry seal cover

Features

Gauge: 65 mil.

Nominal capacity: 2.9 USG / 11.0 L

Stack performance: 300 lbs.*

Tare weights: Body: .99 lbs. / .45 kgs.

Cover: : .34 lbs. / .15 kgs.

Note: *Ratings will be reduced with uneven load distribution.

Specifications with Cover

Dimensions: 11-7/16"D X 9-1/4"H

Maximum capacity: 3.02 USG / 11.4 L

Tare weight: 1.33 lbs. / .60 kgs.

Colors

Standard: White, Black and Natural

Custom: Available at manufacturer's discretion

Decorating Options

Silk - Screening: 30"W X 5-1/2"H

Four or six* color offset printing

Print area: 32"W X 5-1/2"H

Note: *Where available

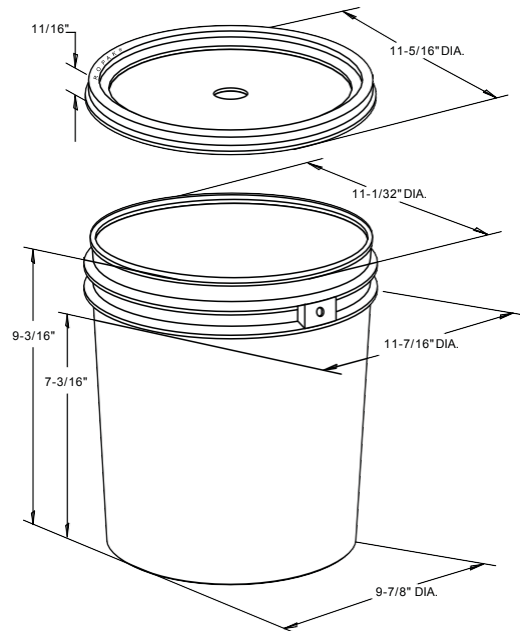

Shipping Data

Qty. per pallet:

Gross Weight (lbs./kgs.)**:

Den. (lbs./C.F./kgs./m3):

Length (in./cm.):

Width (in./cm.):

Height (in./cm.):

Bodies

144

142.6/64.8

4.5/72.7

48/121.9

36/91.4

31.5/80

Covers

1,728 (24 boxes of 72)*

587.5/259.2

8.5/132.3

47/119.4

35.3/89.7

72/182.9

Filled Containers

60 (12 per layer/5 layers high)

Pallet height: 49.75"

Estimated truckload quantity of 9,504 bodies and covers***

Notes: *Bulk pack also available

**Weight does not include pallet/packaging

***Truckload quantity based on 53' trailer

Materials

FDA approved materials

Resin: Body: High-Density Polyethylene (HDPE)

Cover: High-Density Polyethylene (HDPE)

MSDS Sheets available upon request

Optional Carrying Handle