

IF YOU...



MIX IT. FILL IT. PACK IT. SHIP IT.

WE HAVE A PRODUCT FOR YOU



Part #	57WC63
Neck Width	63mm
Cap Liner	Unlined - No Liner
Gasket	EPDM Rubber Gasket
Color	Natural
Material	HDPE
Case Pack	475 ea.
Case Dimensions	15" x 15" x 20"

□ - LAYOUT NUMBER
 ○ - CRITICAL CHARACTERISTIC
 ○ - KEY CRITICAL CHARACTERISTIC

FOR REFERENCE ONLY UNLESS STAMPED OTHERWISE

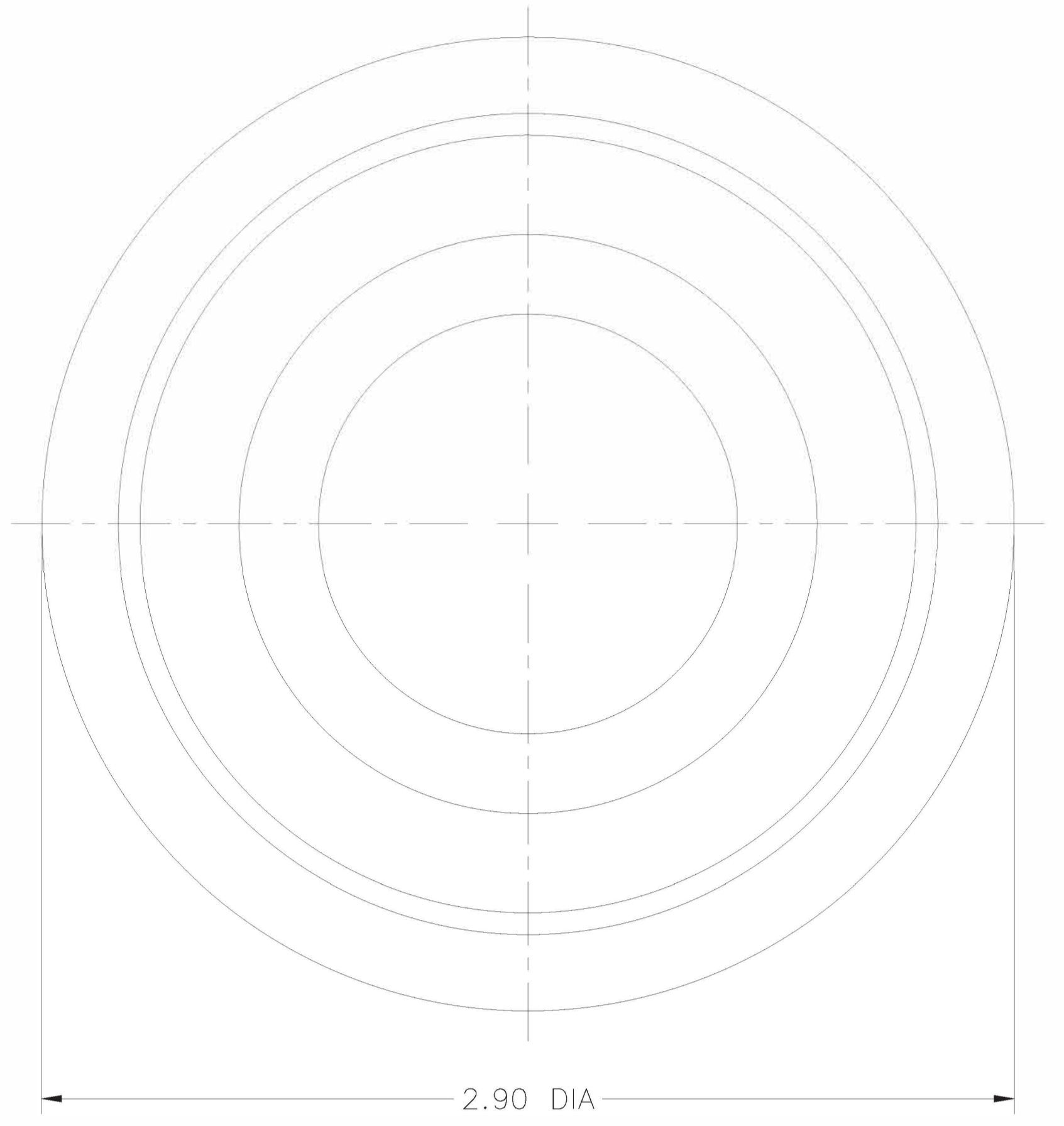
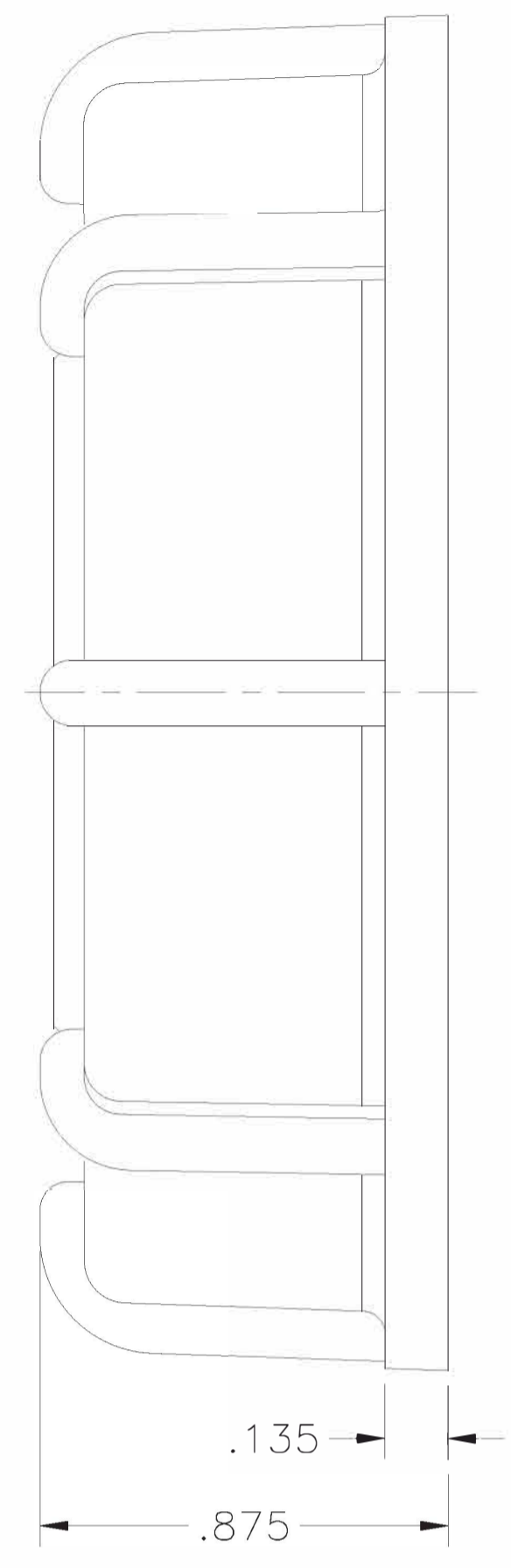
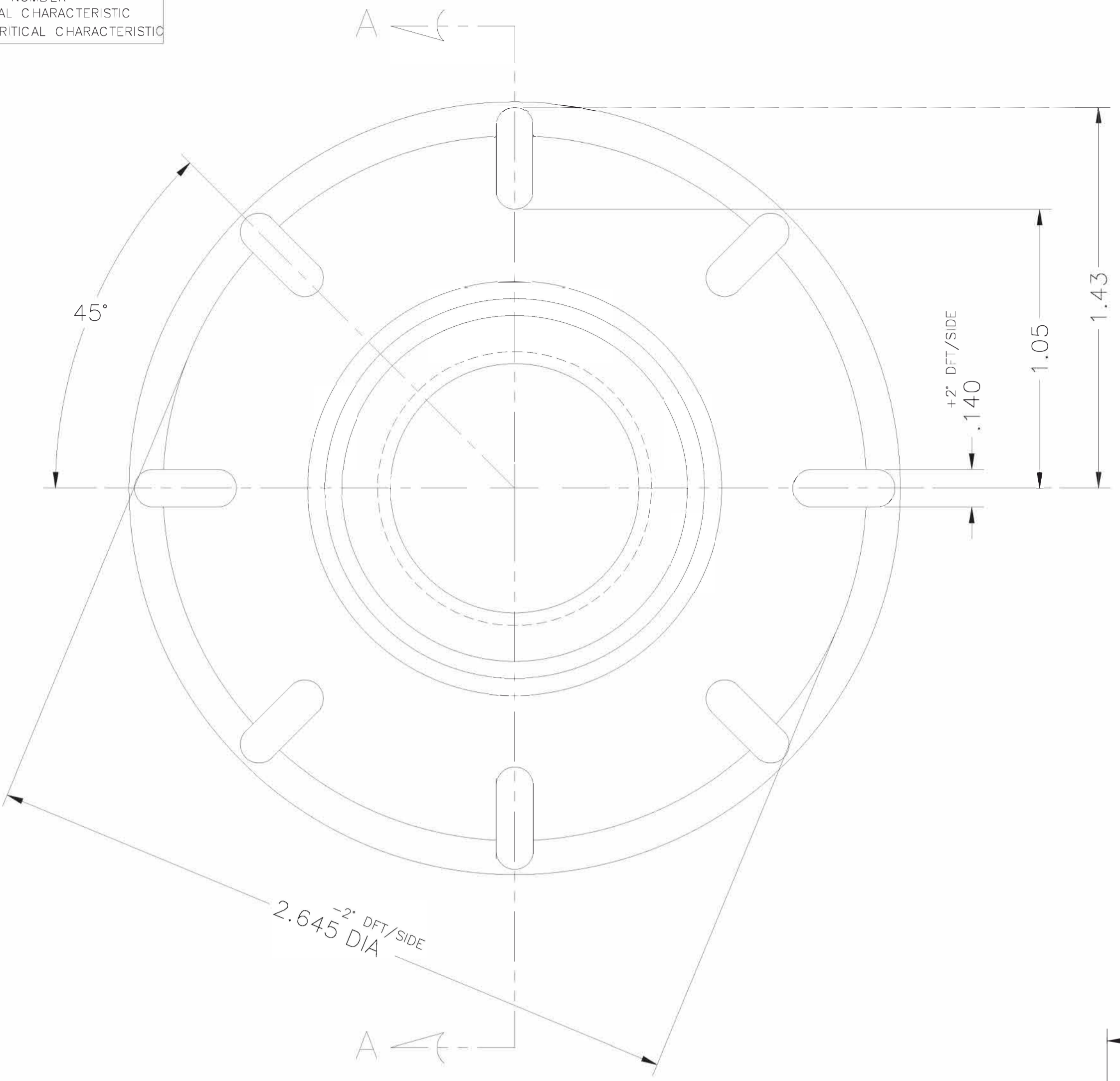

NOTES:

- CENTER THREADS ARE 3/4-14 NPT TAPERED WITH 2° DRAFT/SIDE X .50 DEEP.
- ALL THREAD WEN ENDED SOULD BE WORKED TO A SMOOTH RADIUS.
- LINER ITEM# 6110-000

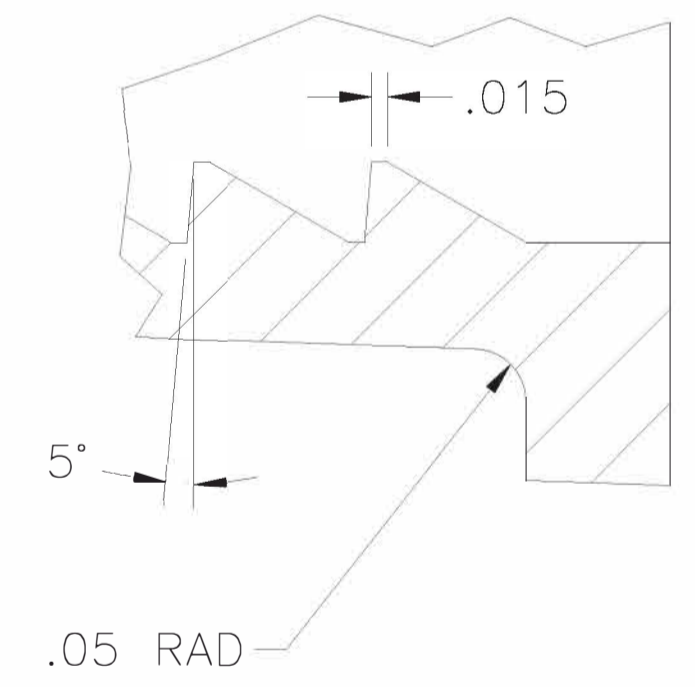
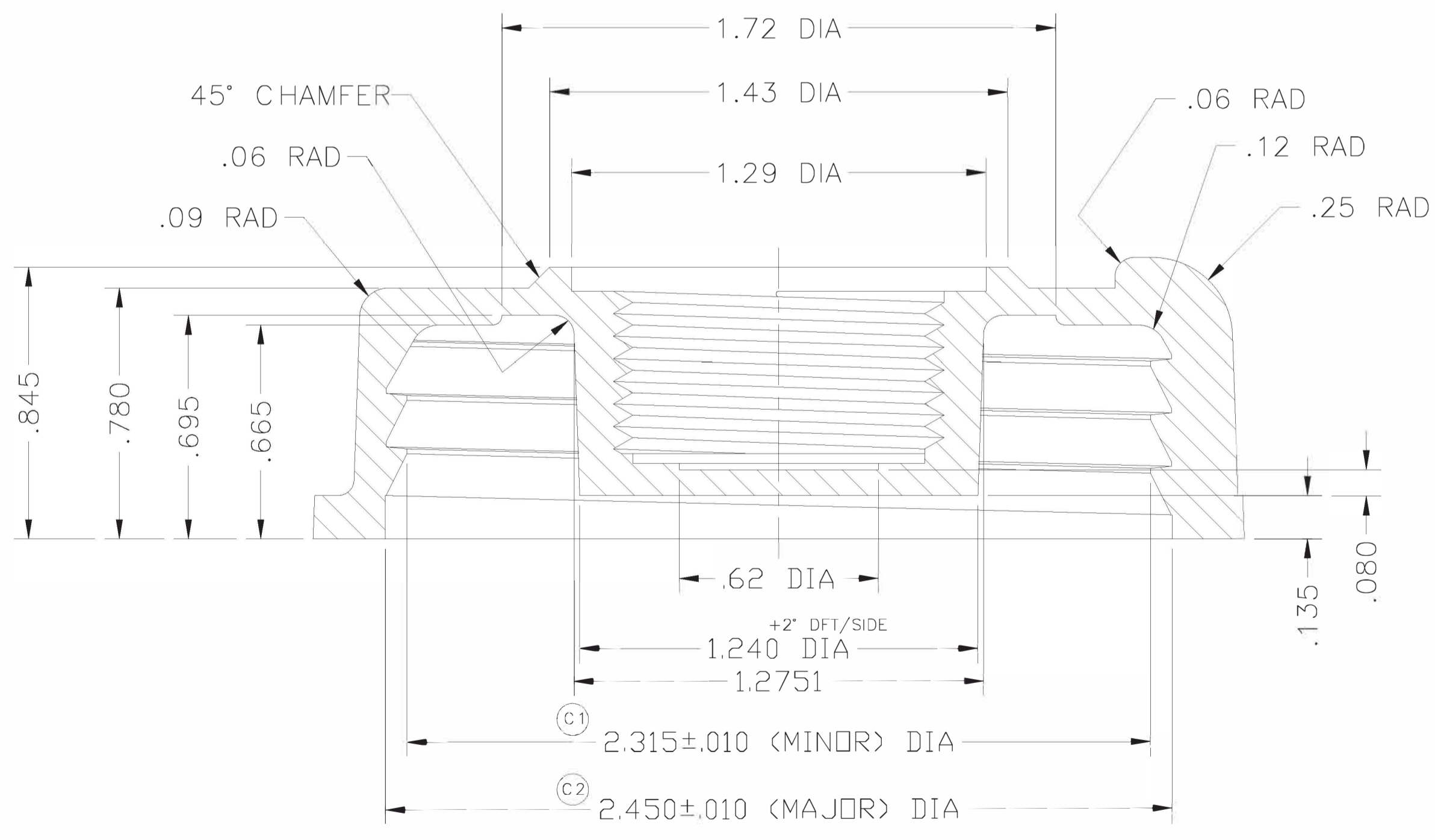

THREAD DETAIL SHOWN 4X SIZE

63MM CLOSURE
 6 THREADS PER INCH
 .100 "S" DIMENSION
 2 1/2 FULL TURNS

SECTION A-A

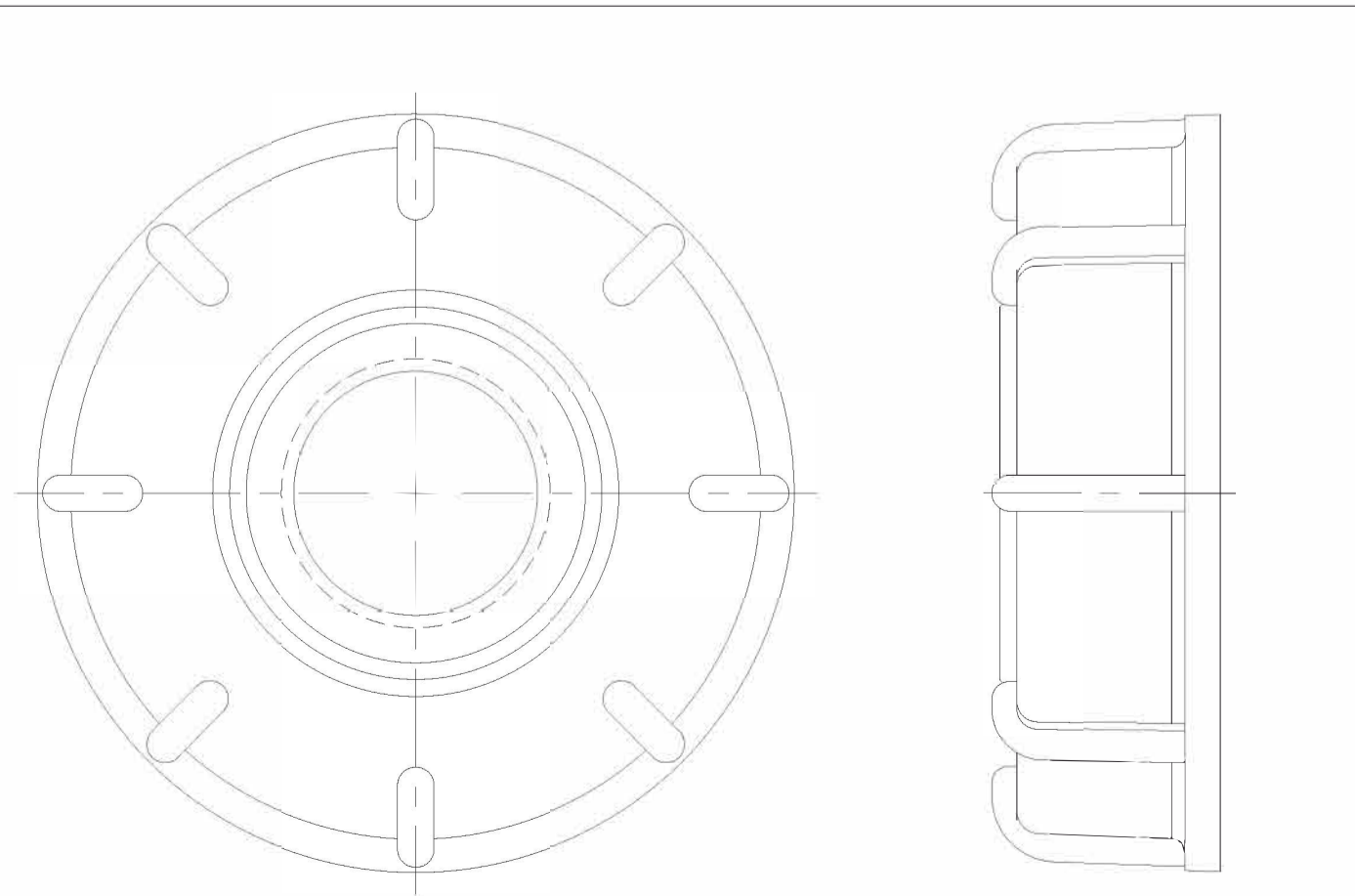

ACTUAL SIZE

DRAWN BY: RFB	DATE: 4/6/93	REVISED: 12/17/04
CHECKED BY: -	DATE: -	SCALE FACTOR: 2:1

The CARY COMPANY Est. 1895

TOLERANCES UNLESS OTHERWISE SPECIFIED		MATERIAL: PRIMARY MATERIAL : POLY 1 S-CP2020
ITEM NUMBER: 8728-000		DO NOT SCALE PRINT

DRAWING DESCRIPTION: 63MM CAP-POLYPROPYLENE-W/ 3/4 NPT	
SHEET 1 OF 1	
DRAWING NUMBER: 8728-000	

ECN.	DATE	LET.	CHANGE	BY
E04-032	12/04	C2	"T" 2.450±.010 WAS 2.445±.005	ES
		C1	"E" 2.315±.010 WAS 2.315±.005	ES
03-012	7/03	B	CHANGED MATERIAL	ES
01-017	9/01	A	ADDED PRIMARY MATERIAL	KE

FOR REFERENCE ONLY UNLESS STAMPED OTHERWISE

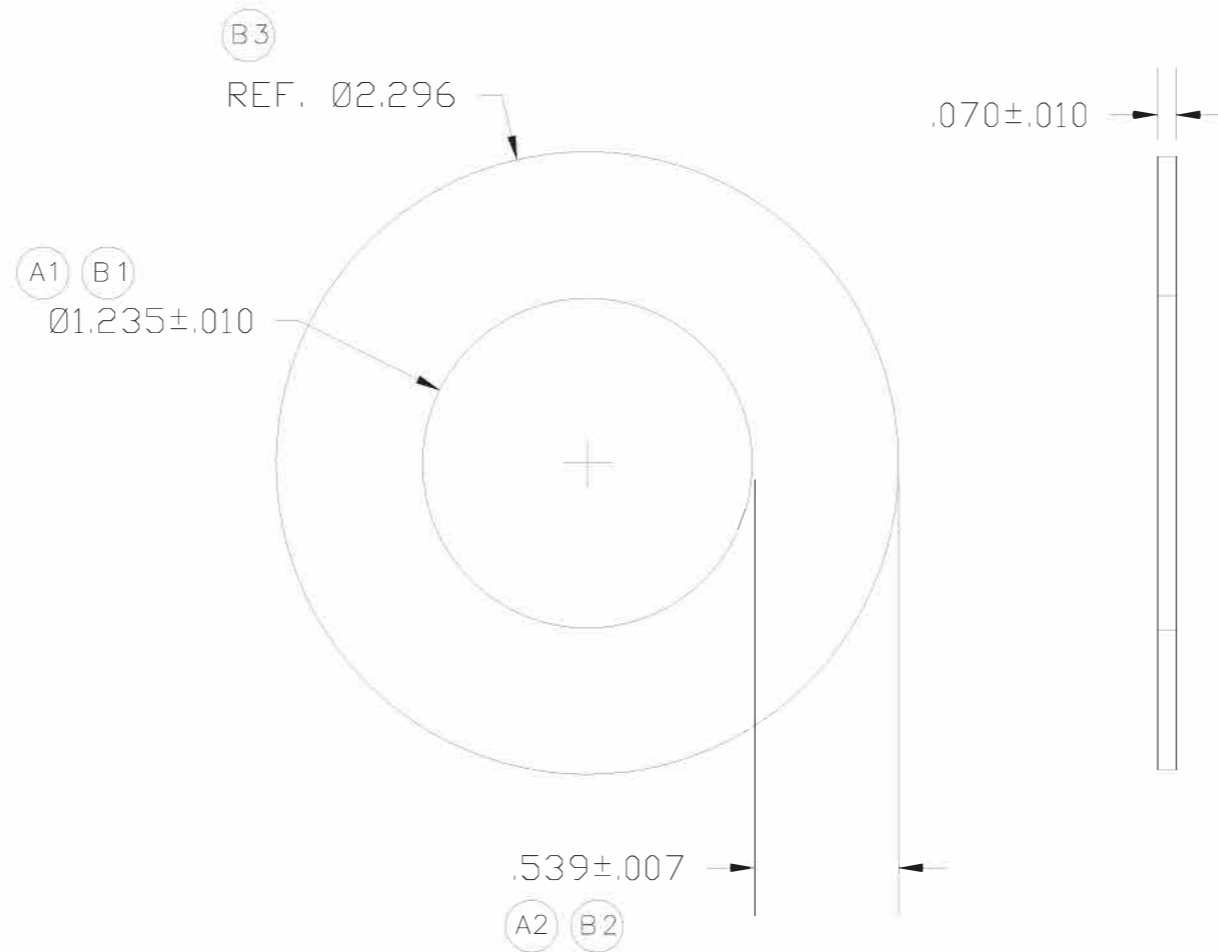

DRAWN BY: EJS		DATE: 11/30/04		REVISED: 12/2/05		 The CARY COMPANY Est. 1895
CHECKED BY: -		DATE: -		SCALE FACTOR: 1:1		
TOLERANCES UNLESS OTHERWISE SPECIFIED		MATERIAL: 55 DUROMETER WHITE EPDM		DRAWING DESCRIPTION: GASKET - 63MM 3/4 NPT		
ITEM NUMBER: 7947-000 / 8728-204		SHEET <u>1</u> OF <u>1</u>		DRAWING NUMBER:		

ECN.	DATE	LET.	CHANGE	BY
05-025	12/05	B1	1.235±.010 WAS 1.255±.015	LB
		B2	.539 ±.007 WAS .521 ±.007	
		B3	ADDED REF.	
E05-001	1/05	A2	.521±.007 WAS .518±.007	ES
		A1	Ø1.255 WAS Ø1.260	

DO NOT SCALE PRINT