

IF YOU...

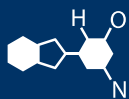

MIX IT. FILL IT. PACK IT. SHIP IT.

WE HAVE A **PRODUCT** FOR YOU

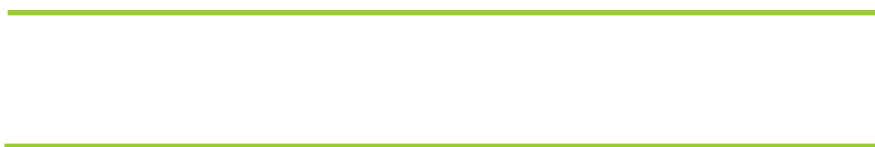

Part #	57WCAO
Neck Width	70 mm
Color	Natural
Material	PE



HIGH DENSITY POLYETHYLENE RING/FS-60-B

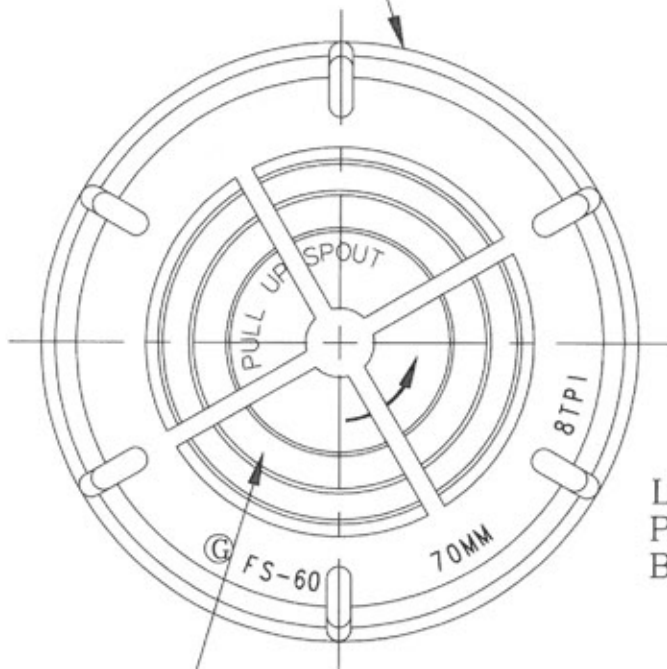

HIGH DENSITY POLYETHYLENE CAP/FS-10-B-5

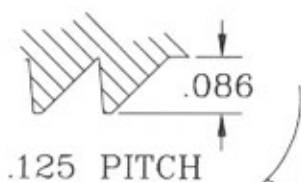

THREAD SPECS	
S	.03 MINIMUM
T	ø2.767 MINIMUM
E	ø2.650 / ø2.613
TPI	8 THDS. PER INCH

EPDM SEALING GASKET

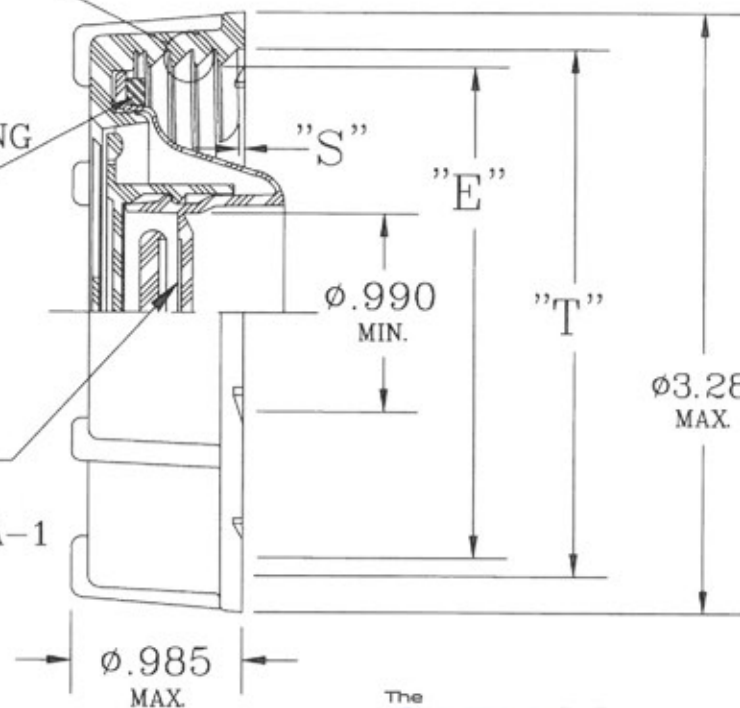

LOW DENSITY POLYETHYLENE BODY/FS-60-A-1

The **CARY** COMPANY
Est. 1895

NOTE: THIS IS NOT A SHOP DRAWING

NOTE: MATERIALS USED MEET FDA REQUIREMENTS

BREAK ALL SHARP EDGES WITH 1/64" RADIUS, UNLESS OTHERWISE SPECIFIED		DATE	DRAWN BY				DETAIL NAME		FS-60 SCREW CAP	
		5/10/95	BNY				TOOL ASSY. NAME			
THE FOLLOWING TOLERANCES APPLY UNLESS OTHERWISE SPECIFIED:		SCALE	CHECKED				PRODUCT		TOOL ASS'Y NUMBER	
		NTS	DRL	G	ADDED FS-60 70MM 8TPI	10/20/14	SCK	DRAWING NUMBER		
ANGLES	±1/4"	APPROVED	F	REDRAWN/NO CHANGES	5/10/95	BNY	FOR		DETAIL NUMBER	
HUNDRETH	±.015		CHANGE NUMBER	CHANGE	DATE	BY	MATERIAL		FS-60	
THOUSANDTH	±.002						SEE NOTATIONS ABOVE		TEMPER	