

# IF YOU...

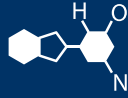

MIX IT. FILL IT. PACK IT. SHIP IT.

# WE HAVE A PRODUCT FOR YOU

Part #57WP2K

Round Plastic Pails

## 2 Gallon Pink Plastic Pail with Metal Handle (P4 Series)



The  
**CARY**COMPANY  
Est. 1895

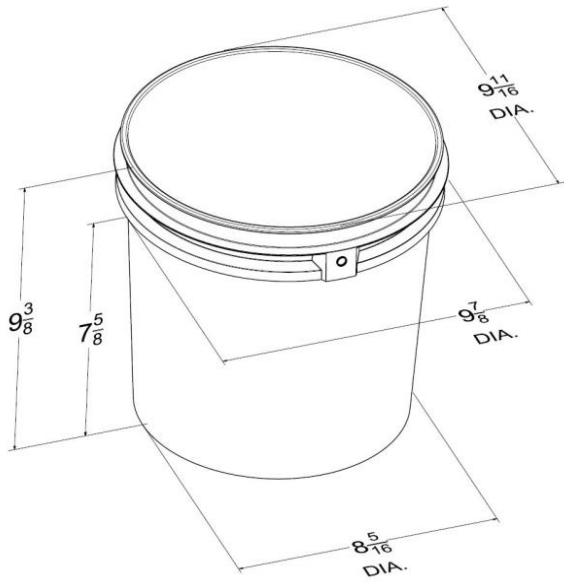

Available with All  
Plastic or Metal  
Handles

---

**Tear Strip Lids  
with Gasket**

**SPECIFICATIONS:**

Height.....	9.375"
Height with Lid.....	9.500"
Outer Diameter at Top.....	9.688"
Outer Diameter at Top with Lid.....	10.063"
Thickness.....	65 mil
Volume.....	2.0 USG Nominal Capacity, 2.22 USG Max Capacity
Tare Weight.....	0.902 lbs. Pail, 1.214 lbs. Pail with Lid

**User Guidelines:** End users must ultimately make their own determination as to the suitability or compatibility of our products for his or her intended use and compliance status of the final product before using. Tests including but not limited to expected fill volume, hot fill compatibility, individual stacking procedures and compatibility with end user production equipment should be completed and verified by end user prior to purchase. This is general sales information only. Measurements are all approximates, sizes and dimensions contained in the specifications may vary. Cary reserves the right to make modifications to any specifications without notice.