

IF YOU...

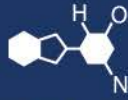

MIX IT. FILL IT. PACK IT. SHIP IT.

WE HAVE A PRODUCT FOR YOU

Part #: 57WP2N



The
CARYCOMPANY
Est. 1895

1195 W. Fullerton Ave. | Addison, IL 60101 | T: 630.629.6600 | F: 630.629.3690 |

2-GALLON PAIL (PP-2GP)

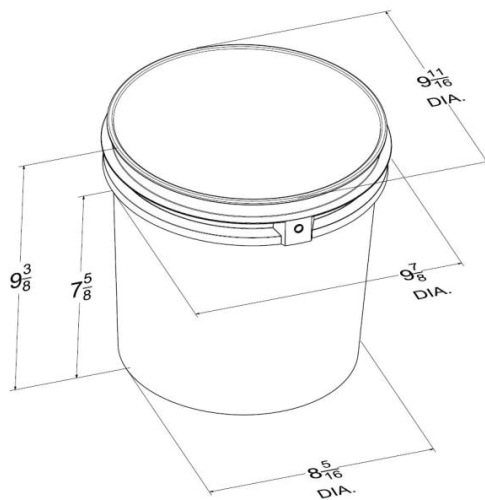

SPECIFICATIONS:

Height.....	9.375"
Height with Lid.....	9.500"
Outer Diameter at Top.....	9.688"
Outer Diameter at Top with Lid.....	10.063"
Thickness.....	.65 mil
Volume.....	2.0 USG Nominal Capacity, 2.22 USG Max Capacity
Tare Weight.....	0.902 lbs. Pail, 1.214 lbs. Pail with Lid

User Guidelines: End users must ultimately make their own determination as to the suitability or compatibility of our products for his or her intended use and compliance status of the final product before using. Tests including but not limited to expected fill volume, hot fill compatibility, individual stacking procedures and compatibility with end user production equipment should be completed and verified by end user prior to purchase. This is general sales information only. Measurements are all approximates, sizes and dimensions contained in the specifications may vary. The Cary Company reserves the right to make modifications to any specifications without notice.

**Made from FDA
 Approved, 100%
 Prime Virgin HDPE**

**Available in
 Bundle Quantities
 of 240 or 360**

**Available with All
 Plastic or Metal
 Handles**

**Tear Strip Lids
 with Gasket**

**Estimated T/L
 Quantity 14,400
 Pails & Lids**