

# IF YOU...

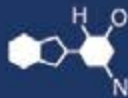

MIX IT. FILL IT. PACK IT. SHIP IT.

# WE HAVE A **PRODUCT** FOR YOU

Part #: 67W02W

---

---



---

The  
**CARY**COMPANY  
Est. 1895

1195 W. Fullerton Ave. | Addison, IL 60101 | T: 630.629.6600 | F: 630.629.3690 |

THE INFORMATION CONTAINED IN THIS DRAWING IS THE SOLE PROPERTY OF THE CARY COMPANY. ANY UNAUTHORIZED USE, TRANSMISSION, OR REPRODUCTION IN PART OR AS A WHOLE WITHOUT THE WRITTEN PERMISSION IS STRICTLY PROHIBITED.

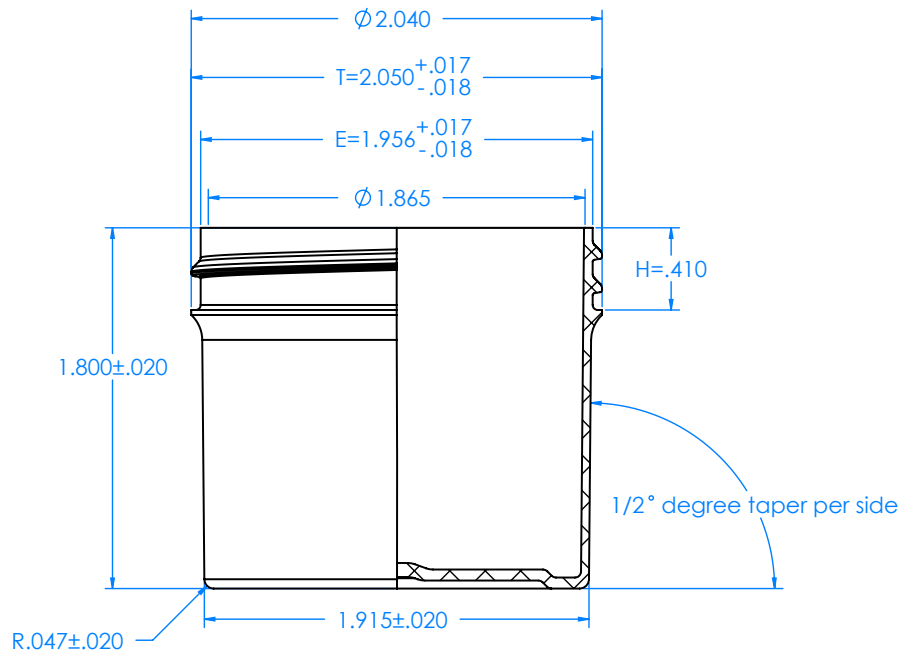

DECORATION AREA

WRAP: 5.88 inches

HEIGHT: 1.00 inches

DRAFT:  $1/2^\circ$  per side

| REVISIONS                |      |             |    | UNLESS OTHERWISE NOTED DIMENSIONS ARE IN INCHES TOLERANCES ARE: |      | MATERIAL:        | POLYPROPYLENE          | PART DESCRIPTION:  |                             |
|--------------------------|------|-------------|----|---|------|------------------|------------------------|--|-----------------------------|
| REV.                     | DATE | DESCRIPTION | BY | DIM.  | TOL. | APPROX WEIGHT:   | 9 grams                | <b>2 oz. White PP Plastic Jar,<br/>Straight Sided,<br/>53mm 53-400</b> |                             |
|                          |      | NEW         |    |   |      | APPROX OVERFLOW: | 75 ml                  |  |                             |
|                          |      |             |    | .00   | .030 | THREAD:          | "M" STYLE, 6 TPI PITCH |  |                             |
|                          |      |             |    | .000  | .020 |                  |                        |  |                             |
| COMMENTS: MADE IN U.S.A. |      |             |    | DRAWN BY: J.T. APPROVED BY: C.M. DATE: 02/17/2020               |      | SCALE: 1:1       | DO NOT SCALE DRAWING   | PART CODE: 67W02W  | REV. <b>A</b> SIZE <b>A</b> |