

# IF YOU...

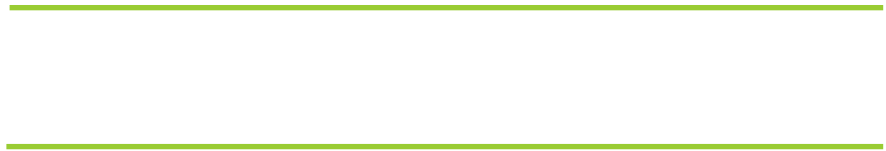

MIX IT. FILL IT. PACK IT. SHIP IT.

# WE HAVE A PRODUCT FOR YOU



|              |                      |
|--------------|----------------------|
| Part #       | 67W23W               |
| Capacity     | 23 oz.               |
| Color        | White                |
| Material     | HDPE                 |
| Dimensions   | 3.6" Dia. x 4.75"H   |
| Neck Finish  | 89-400               |
| Neck Width   | 89mm                 |
| BPA Free     | Yes                  |
| FDA Approved | Yes                  |
| Case Pack    | 144 ea.              |
| Pallet Pack  | 2,304 ea. (16 Cases) |



23 Ounce-Wide Mouth Container

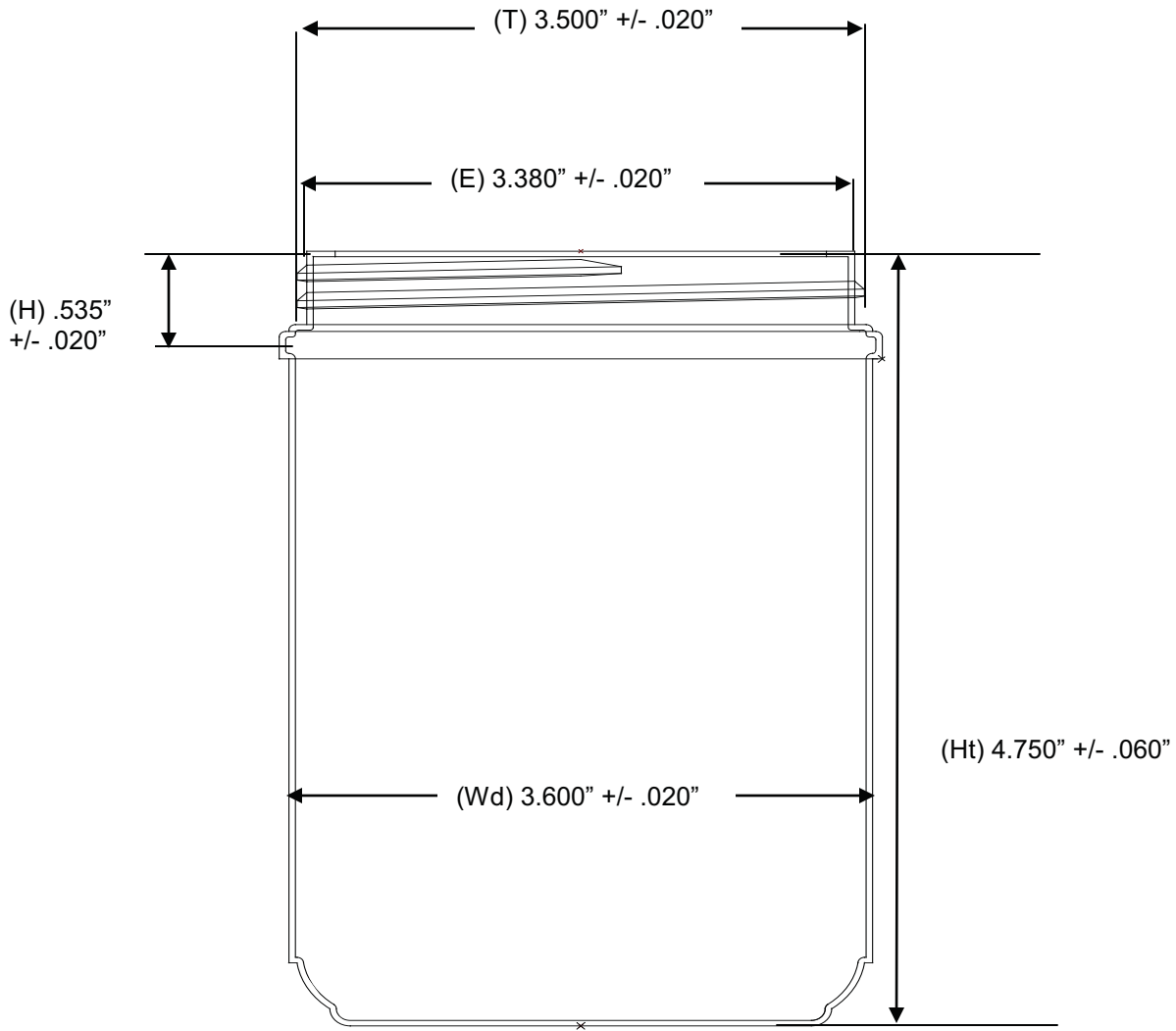

|   |   |
|---|---|
| <b>Lid:</b> 89mm                            | <b>Gram Weight:</b> 34.5 grams +/- 2.0                |
| <b>Wall Thickness Minimum:</b> .015"        | <b>Colors: Stock:</b> White (custom colors available) |
| <b>Neck Finish:</b> 89mm Single Lead Thread | <b>Material:</b> High Density Polyethylene            |



PH 630-629-6600 - FX 630-629-3690  
 1195 W. FULLERTON AVE. - ADDISON, IL 60101  
 WWW.THECARYCOMPANY.COM