

IF YOU...



MIX IT. FILL IT. PACK IT. SHIP IT.

WE HAVE A PRODUCT FOR YOU



Part #	67W45F
Neck Width	43mm
Neck Finish	43-485
Cap Liner	Uni-Foam™ .020 Foam PS-113 Pressure Sensitive (Imprinted with "Sealed for Freshness" in Black)
Liner Compatability	Glass, PE (HDPE, LDPE), PET, PP, PVC, Universal
Cap Dispensing	.200" (5 holes) Sift Single-Flap Dispenser
Color	Black
Material	PP
Case Pack	1,400 ea.
Pallet Pack	58,000 ea. (42 Cases)
FDA Approved	Yes
Industries	Food & Beverage
Note	Pressure sensitive liners are not considered a form of tamper evident seal



PH 630-629-6600 - FX 630-629-3690
 1195 W. FULLERTON AVE. - ADDISON, IL 60101
 WWW.THECARYCOMPANY.COM

43mm 485 FlapMate™

MATERIAL: POLYPROPYLENE

**BOTTLE FINISH: 485
 FITS MOST C.C.M.A. BOTTLE
 FINISHES**

**TORQUE RECOMMENDATION:
 17-27 IN LBS. THIS REQUIREMENT
 MAY VARY DEPENDING UPON
 BOTTLE MATERIAL, NECK FINISH,
 AND CAPPING EQUIPMENT.**

**LOGO INSERT
 TYPICAL LOGO DEPTH/HEIGHT IS
 .005". EACH LOGO GRAPHIC
 SHOULD BE EVALUATED ON A
 CASE BY CASE BASIS.**

**THE CLOSURE DIMENSIONS
 SHOWN ARE THOSE WHICH
 HAVE GENERALLY BEEN FOUND
 TO BE FUNCTIONAL BASED ON
 INDUSTRY EXPERIENCE
 BECAUSE OF VARIABILITY IN
 GLASS AND PLASTIC CONTAINER
 FINISHES. EACH
 CLOSURE/FINISH SYSTEM
 SHOULD BE INDIVIDUALLY
 EVALUATED AND TESTED TO
 ENSURE IT MEETS APPLICABLE
 PERFORMANCE CRITERIA. SEE
 QUALITY ASSURANCE
 SPECIFICATIONS FOR
 ADDITIONAL INFORMATION.**

SHT. 1 OF 2
 DATE: 26 July 2010
 DRAWN BY: BMD
 AUTHORIZED FOR USE BY:
 AMBER CARLILE
 DATE:
 JUNE 20, 2011

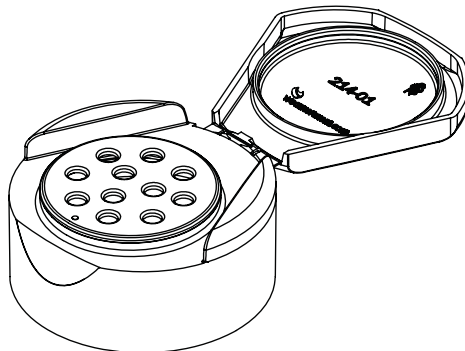

FLAP IN FULL OPEN

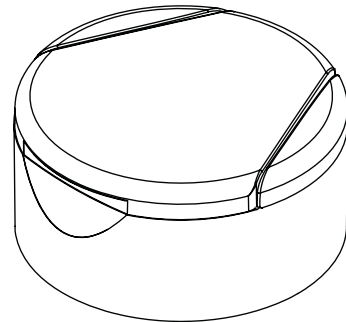

FLAP FULLY CLOSED

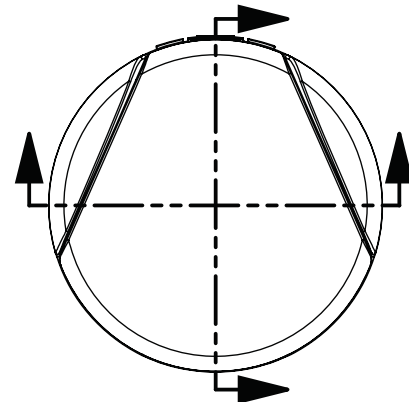
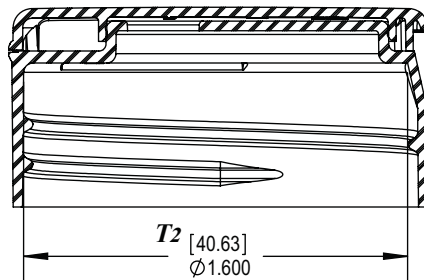

SEE THREAD DETAIL

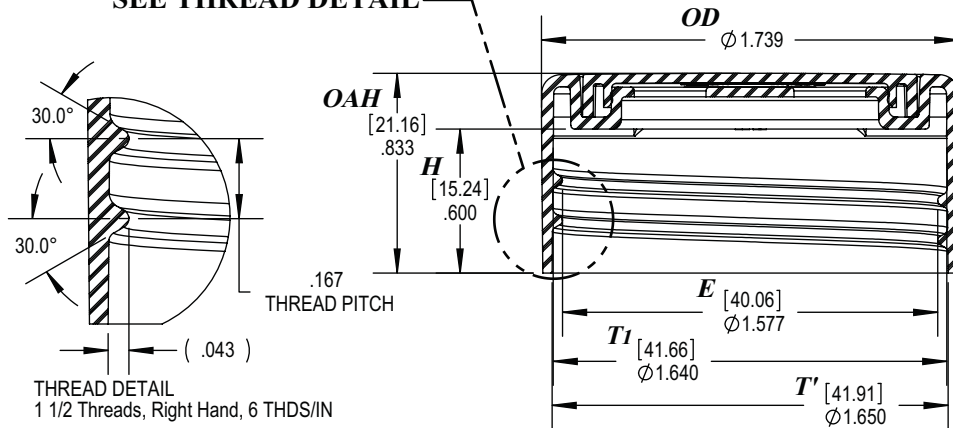

**THREAD DETAIL
 1 1/2 Threads, Right Hand, 6 THDS/IN**

**THEORETICAL PART WEIGHT: SEE SHEET 2
 OPENING FORCE: 15 4.0LBS**

**43mm-485
 FlapMate™**

S-214-00-03-AA



PH 630-629-6600 - FX 630-629-3690
 1195 W. FULLERTON AVE. - ADDISON, IL 60101
 WWW.THECARYCOMPANY.COM

43mm 485 FlapMate™

MATERIAL: POLYPROPYLENE

BOTTLE FINISH: 485
 FITS MOST C.C.M.A. BOTTLE FINISHES

TORQUE RECOMMENDATION:
 17 27 IN LBS. THIS REQUIREMENT
 MAY VARY DEPENDING UPON
 BOTTLE MATERIAL, NECK FINISH,
 AND CAPPING EQUIPMENT.

LOGO INSERT
 TYPICAL LOGO DEPTH/HEIGHT IS
 .005". EACH LOGO GRAPHIC
 SHOULD BE EVALUATED ON A
 CASE BY CASE BASIS.

THE CLOSURE DIMENSIONS
 SHOWN ARE THOSE WHICH
 HAVE GENERALLY BEEN FOUND
 TO BE FUNCTIONAL BASED ON
 INDUSTRY EXPERIENCE
 BECAUSE OF VARIABILITY IN
 GLASS AND PLASTIC CONTAINER
 FINISHES, EACH
 CLOSURE/FINISH SYSTEM
 SHOULD BE INDIVIDUALLY
 EVALUATED AND TESTED TO
 ENSURE IT MEETS APPLICABLE
 PERFORMANCE CRITERIA. SEE
 QUALITY ASSURANCE
 SPECIFICATIONS FOR
 ADDITIONAL INFORMATION.

SHT. 1 OF 2
 DATE: 26 July 2010
 DRAWN BY: BMD
 AUTHORIZED FOR USE BY:
 AMBER CARLILE
 DATE: JUNE 20, 2011

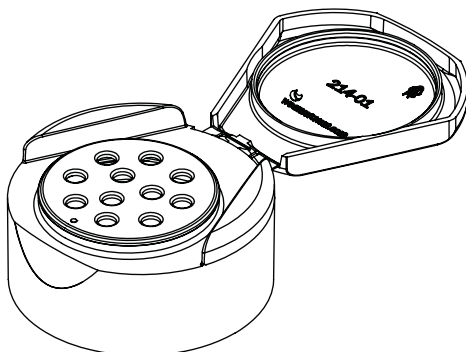

.125" SIFT HOLE (11X)
 REFERENCE PART WEIGHT: 6.14g

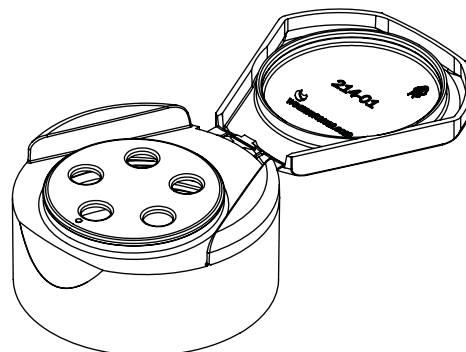

.200" SIFT HOLE (5X)
 REFERENCE PART WEIGHT: 6.13g

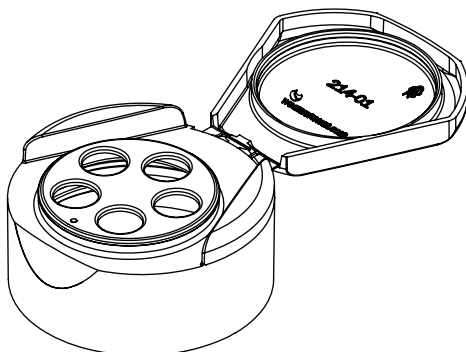

.300" SIFT HOLE (5X)
 REFERENCE PART WEIGHT: 6.02g

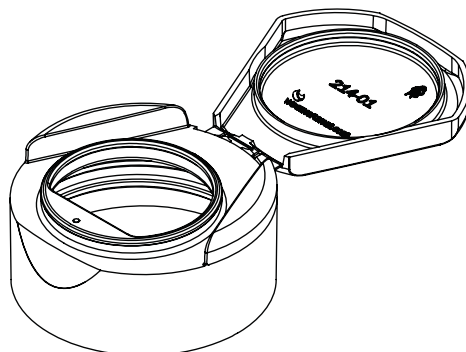

FULL POUR HOLE
 REFERENCE PART WEIGHT: 5.76g

SIFT LOGO
 USED FOR ALL
 SIFT OPTIONS

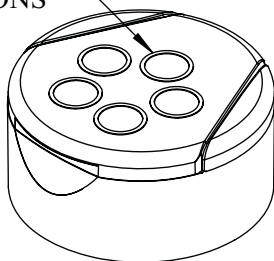

NO LOGO
 USED FOR FULL
 POUR OPTION

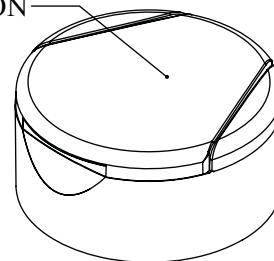

43mm-485
 FlapMate™

S-214-00-03-AA