

IF YOU...

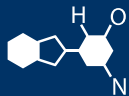

MIX IT. FILL IT. PACK IT. SHIP IT.

WE HAVE A **PRODUCT** FOR YOU

Part #67W7WP

Plastic Caps

70mm 70-400 White Smooth Plastic Cap, Unlined



The
CARYCOMPANY
Est. 1895

1195 W. Fullerton Ave. | Addison, IL 60101 | T: 630.629.6600 | F: 630.629.3690 | TheCaryCompany.com

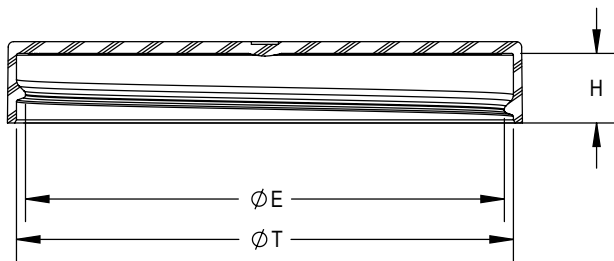
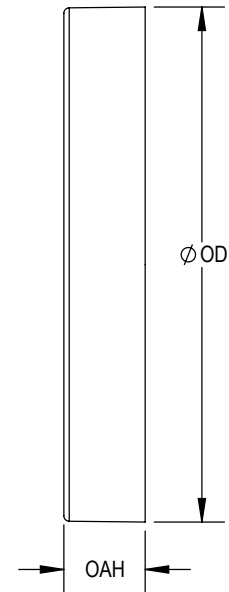
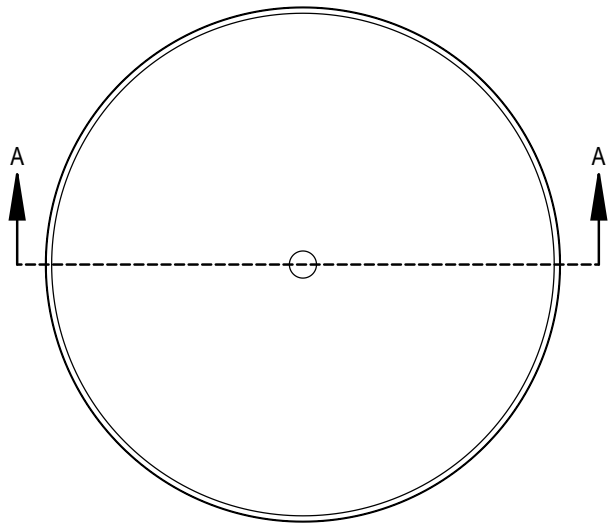

SECTION A-A

THREAD DETAIL:
6 THREADS PER INCH, 0.167" PITCH

REFERENCE	TOLERANCE	UNITS	DIMENSION
E	±0.015 [0.38]	in [mm]	2.650 [67.31]
T	±0.020 [0.51]	in [mm]	2.750 [69.85]
H	±0.015 [0.38]	in [mm]	0.392 [9.96]
OAH	±0.020 [0.51]	in [mm]	0.450 [11.43]
OD	±0.025 [0.64]	in [mm]	2.850 [72.39]
PART WEIGHT	± 1.5	g	7.8

STATIC TORQUE RECOMMENDATION
28-50 in-lbs
THIS REQUIREMENT MAY VARY DEPENDING
UPON BOTTLE MATERIAL, NECK FINISH, AND
CAPPING EQUIPMENT

DRAWING TYPE : **CUSTOMER**

REPLACES DRAWINGS:

DIMENSIONS ENCLOSED IN ()
INDICATE REFERENCE
DIMENSIONS AND NO TOLERANCE
LIMITS ARE ESTABLISHED

TOLERANCES UNLESS OTHERWISE SPECIFIED

DIMENSION (inches)	TOLERANCE	DIMENSION (mm)	TOLERANCE
0-0.787	±0.006	0-20	±0.152
0.788-1.181	±0.008	21-30	±0.203
1.182-2.756	±0.012	31-70	±0.305
2.757-3.937	±0.016	71-100	±0.406
3.938-5.096	±0.020	101-150	±0.508
5.097-7.874	±0.024	151-200	±0.610
7.875-9.843	±0.032	201-250	±0.813

ANGULAR TOLERANCE ± 2°

PROPRIETARY AND CONFIDENTIAL

The
CARY COMPANY
Est. 1895

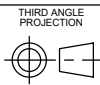

SOLIDWORKS

THIRD ANGLE
PROJECTION

DISTRIBUTION
CODE

D

DRAWING NAME

**70-400 CT CLOSURE
S (Smooth Side Smooth Top)**

DRAWING NUMBER

CQA - 10748

DRAWN BY:

JR

6/3/2016

MATERIAL

POLYPROPYLENE

ENG APPR.

CAN

4/11/2022

MODEL NUMBER:

PM 11104 70-400 CT

QA APPR.

TEM

04/11/2022

SCALE

SHEET SIZE

SHEET

REV.NP

1:1

8.5" X 11"

1 of 3

00.AC

REVISIONS						
DATE	REV.	N/P	PRODUCT DRAWING REQUEST	DESCRIPTION	ENG	DRW
12/02/2013	00	AA		REDRAWN ON NEW FORMATS	JR	JR
01/19/2018	00	AB	PDR 18-067	UPDATED FORMAT AND ASSIGNED NEW PART NUMBER. DIMENSIONAL SPECIFICATIONS UPDATED BASED ON PRODUCTION CAPABILITY. NO STEEL CHANGES OCCURED.	BDG	DAS
4/11/2022	00	AC		UPDATED PART FINISH NOTE, NO STEEL CHANGES HAVE OCCURRED	CAN	CAN

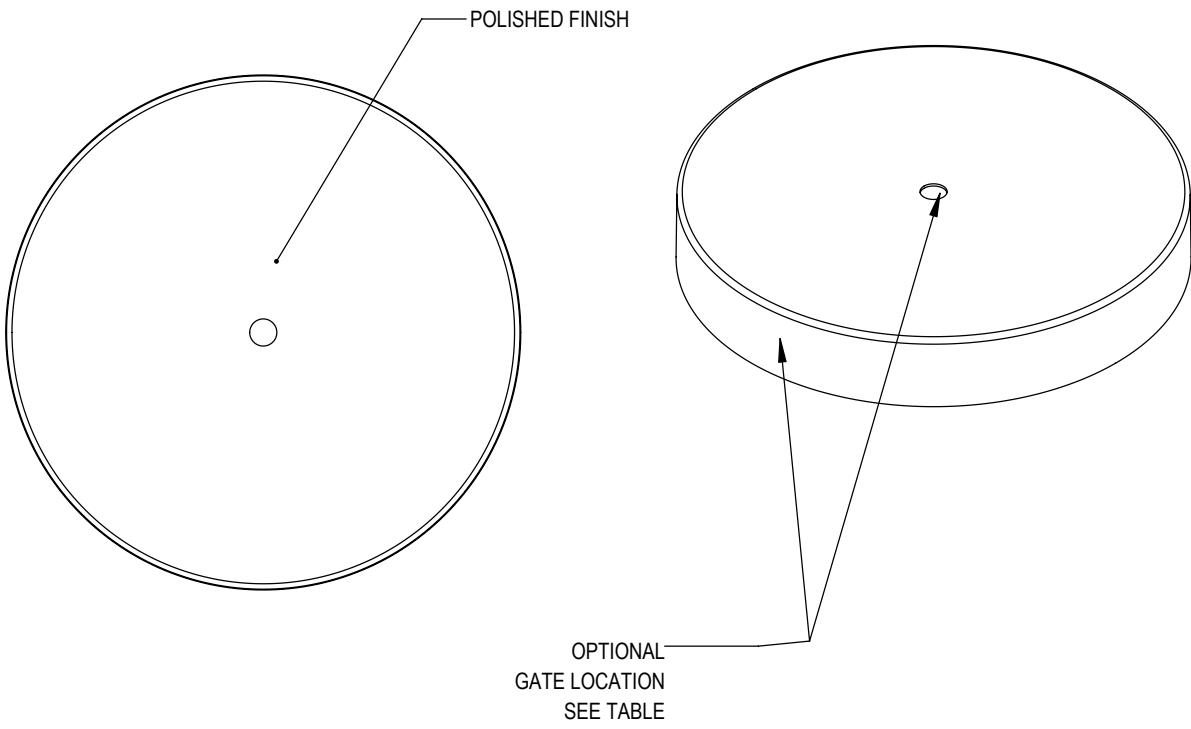

MOLD NUMBER	GATE LOCATION	
	SIDE	TOP
70003	X	
70007	X	
70008		X

DRAWING TYPE : CUSTOMER			
REFERENCES: 70003 70007 70008		DIMENSIONS ENCLOSED IN () INDICATE REFERENCE DIMENSIONS AND NO TOLERANCE LIMITS ARE ESTABLISHED	
TOLERANCES UNLESS OTHERWISE SPECIFIED			
DIMENSION (inches)	TOLERANCE	DIMENSION (mm)	TOLERANCE
0-0.787	±0.006	0-20	±0.152
0.788-1.181	±0.008	21-30	±0.203
1.182-2.756	±0.012	31-70	±0.305
2.757-3.937	±0.016	71-100	±0.406
3.938-5.096	±0.020	101-150	±0.508
5.097-7.874	±0.024	151-200	±0.610
7.875-9.843	±0.032	201-250	±0.813
ANGULAR TOLERANCE ± 2°			
PROPRIETARY AND CONFIDENTIAL			



THIRD ANGLE PROJECTION	DISTRIBUTION CODE	DRAWING NAME	
	D	70-400 CT CLOSURE S (Smooth Side Smooth Top)	
		DRAWING NUMBER	
		CQA - 10748	
DRAWN BY.	JR	6/3/2016	MATERIAL
			POLYPROPYLENE
ENG APPR.	CAN	4/11/2022	MODEL NUMBER:
			PM 11104 70-400 CT
QA APPR.	TEM	04/11/2022	SCALE
			1:1
			SHEET SIZE
			8.5 X 11
			SHEET
			2 of 3
			REV.NP
			00.AC

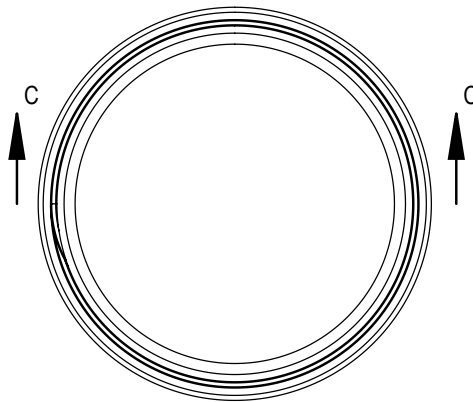

CRITICAL FOR ORIENTATION
 .001" = 2 Degrees in Change
 S' 0.133
 [3.38]

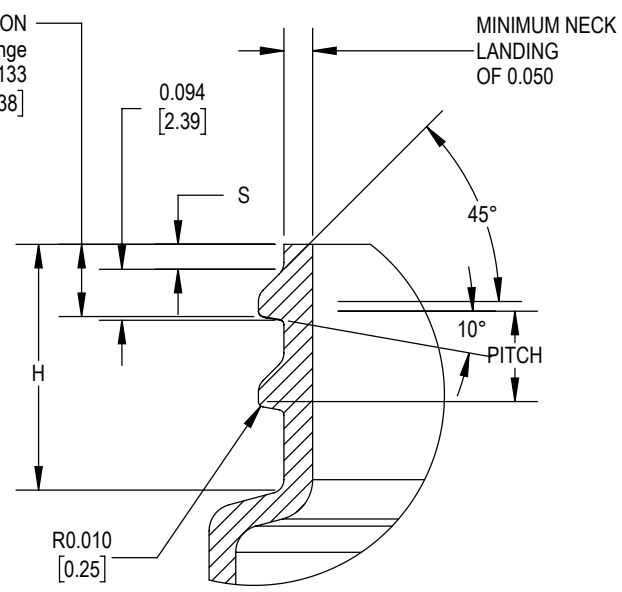

DETAIL THREAD
 SCALE 3 : 1

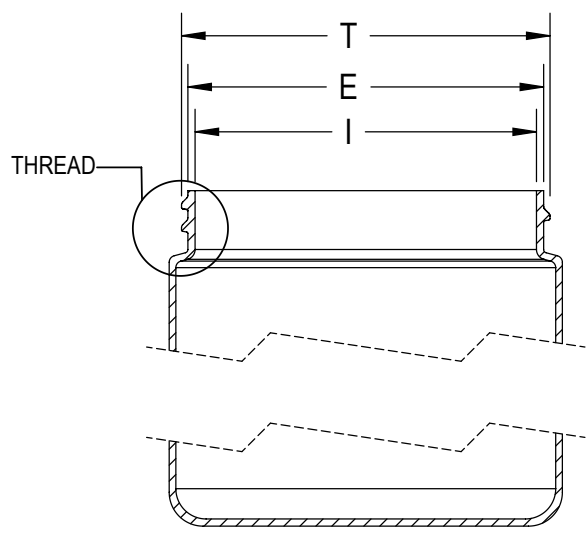

SECTION C-C

REFERENCE	TOLERANCE	UNITS	DIMENSION
E	±0.017 [0.43]	in [mm]	2.625 [66.68]
T	±0.017 [0.43]	in [mm]	2.719 [69.06]
I	MIN	in [mm]	2.232 [56.69]
S	±0.015 [0.38]	in [mm]	0.046 [1.17]
H	MIN	in [mm]	0.408 [10.36]
TPI			6
PITCH		in [mm]	0.167 [4.24]

NOTE: THE NOMINAL ORIENTATION ILLUSTRATED IS BASED ON NOMINAL DIMENSIONS OF BOTH THE CLOSURE AND THE RECOMMENDED NECK FINISH. FOR EXACT ORIENTATION EACH BOTTLE SHOULD BE EVALUATED ON A CASE BY CASE BASIS.

DRAWING TYPE : CUSTOMER

DIMENSIONS ENCLOSED IN () INDICATE REFERENCE DIMENSIONS AND NO TOLERANCE LIMITS ARE ESTABLISHED

TOLERANCES UNLESS OTHERWISE SPECIFIED			
DIMENSION (inches)	TOLERANCE	DIMENSION (mm)	TOLERANCE
0-0.787	±0.006	0-20	±0.152
0.788-1.181	±0.008	21-30	±0.203
1.182-2.756	±0.012	31-70	±0.305
2.757-3.937	±0.016	71-100	±0.406
3.938-5.096	±0.020	101-150	±0.508
5.097-7.874	±0.024	151-200	±0.610
7.875-9.843	±0.032	201-250	±0.813

ANGULAR TOLERANCE ± 2°
 PROPRIETARY AND CONFIDENTIAL

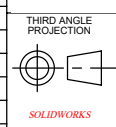

DISTRIBUTION CODE: D
 DRAWING NAME: 70-400 CT CLOSURE RECOMMENDED NECK FINISH
 DRAWING NUMBER: CQA - 10748

DRAWN BY: JR	6/3/2016	MATERIAL		
ENG APPR: CAN	4/11/2022	MODEL NUMBER:		
QA APPR: TEM	04/11/2022	SCALE: 3:4	SHEET SIZE: 8.5 X 11	SHEET: 3 of 3
				REV.N/P: 00.AC