

IF YOU...



MIX IT. FILL IT. PACK IT. SHIP IT.

WE HAVE A PRODUCT FOR YOU



Part #	67WA12
Capacity	12 oz.
Color	Amber
Material	PET
Dimensions	3.5" Dia. x 2.63"H
Neck Finish	89-400
Neck Width	89mm
BPA Free	Yes
FDA Approved	Yes
Case Pack	120 ea.
Pallet Pack	3,600 ea. (30 Cases)



NOTE:

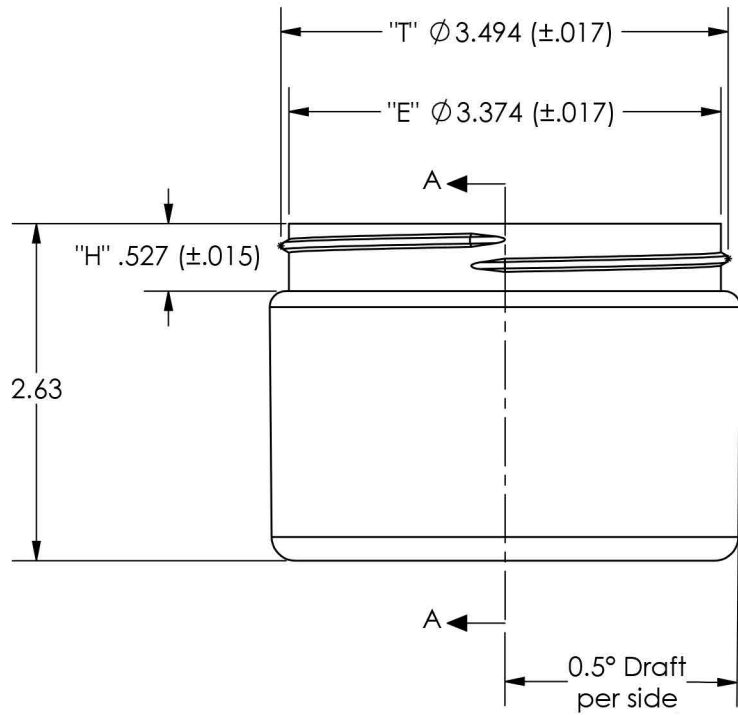

SECTION A-A

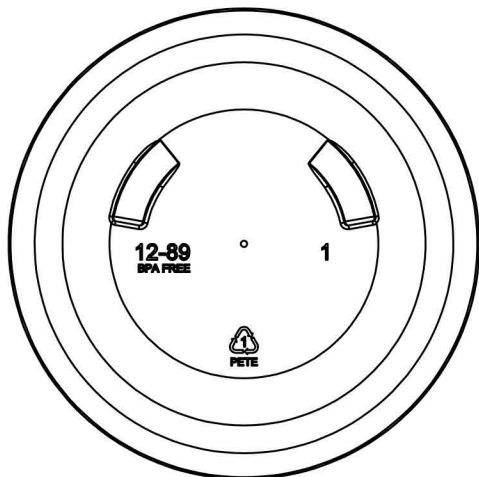
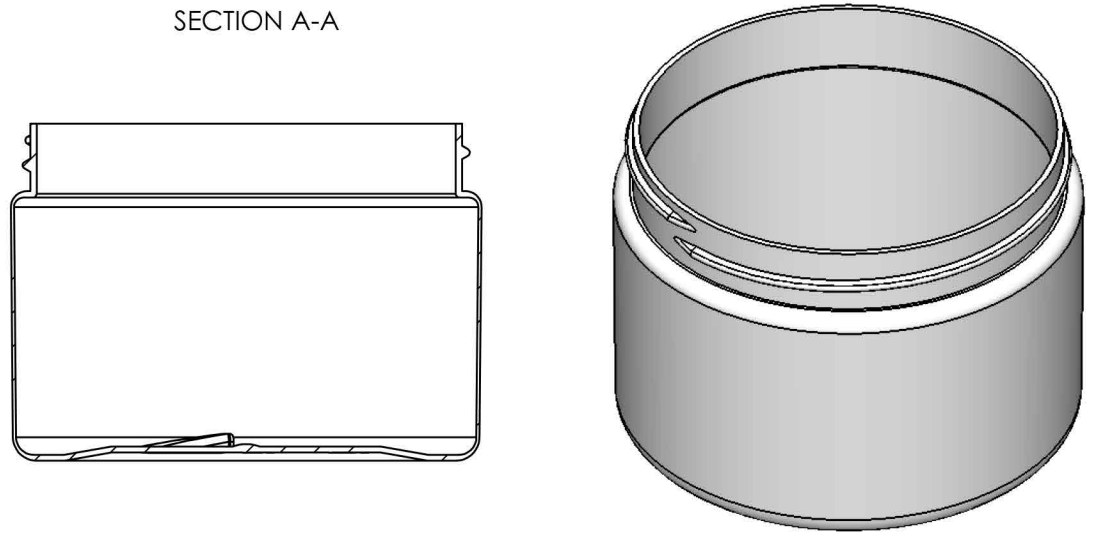

DRAWING NAME: PRELIMINARY PART DWG - JBS1289PT - MBH006-001			
PART NAME: 12 oz 89 mm Jar		PART #: JBS1289PT:MBH006-001	
		2 0 1 4	BY: DATE:
		DRAWN	S.B. 6/11/2014
		CHECKED	S.B. 4/15/2015
		APPROVED	J.R.B. 4/15/2015
THREAD PITCH: 5 T.P.I.		# OF THREAD TURNS: 1 FULL TURNS	
DRAFT ANGLE: 0.5° Degree		PROJECTED COSMETIC FILL: 338 (±11) mL 11.4 (±.4) OZ	
GATE LOCATION: EXTERIOR - CENTER		PROJECTED OVERFLOW: 410 (±11) mL 13.9 (±.4) OZ	
MATERIAL: PETE		PART WEIGHT: 33.3 Grams (±5%)	
		TOLERANCES (UNLESS SPECIFIED) .00 = ±.015 .000 = ±.010	
		DIMENSIONS ARE IN INCHES ANGULAR TOLERANCE ± 1/2 DEGREE	
		THIRD ANGLE PROJECTION	
		SHEET SCALE: FULL SHEET SIZE: A	