

IF YOU...

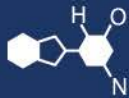

MIX IT. FILL IT. PACK IT. SHIP IT.

WE HAVE A **PRODUCT** FOR YOU

Part #: 67WB08



The
CARYCOMPANY
Est. 1895

1195 W. Fullerton Ave. | Addison, IL 60101 | T: 630.629.6600 | F: 630.629.3690 |

PROPRIETARY AND CONFIDENTIAL:
 THE INFORMATION CONTAINED IN THIS DRAWING IS THE SOLE PROPERTY OF THE CARY COMPANY.
 ANY REPRODUCTION IN PART OR AS A WHOLE WITHOUT THE WRITTEN PERMISSION OF THE CARY COMPANY IS PROHIBITED.

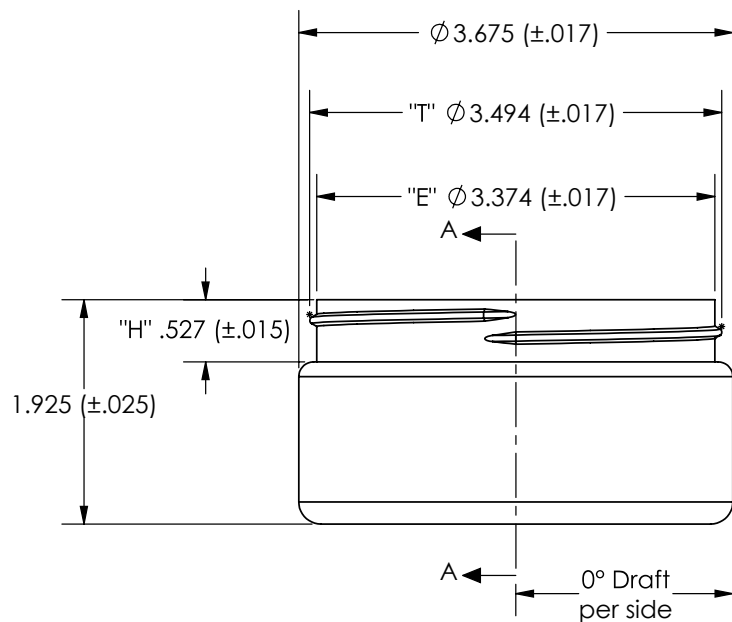

SECTION A-A

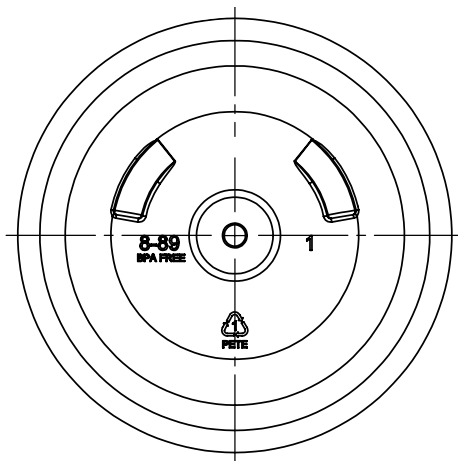
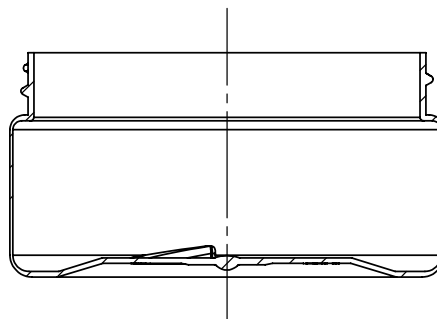

DRAWING NAME: PART DWG - 67WB08			
PART NAME: 8 Oz 89mm 89-400 Black PET Straight Sided Jar		PART #: 67WB08	REV: A
		2019	BY: DATE:
		DRAWN	J.Z. 12/17/2019
		CHECKED	T.S. 3/3/2020
		APPROVED	S.J. 3/3/2020
THREAD PITCH: 5 T.P.I.		# OF THREAD TURNS: 1 FULL TURNS	TOLERANCES (UNLESS SPECIFIED) .00 = ±.015 .000 = ±.010
DRAFT ANGLE: 0° Degree		PROJECTED COSMETIC FILL: 216 (±7) M.L 7.3 (±.2) O.Z	ANGULAR TOLERANCE ± 1/2 DEGREE
GATE LOCATION: EXTERIOR - CENTER		PROJECTED OVERFLOW: 288 (±7) M.L 9.7 (±.2) O.Z	THIRD ANGLE PROJECTION
MATERIAL: PETE		PART WEIGHT: 25 Grams (±5%)	SHEET SCALE: FULL SHEET SIZE: A