

THREAD DETAIL INFORMATION
 6 THREADS PER INCH, 0.167 PITCH
 540° FULL DEPTH THREAD

REFERENCE	TOLERANCE	UNITS	DIMENSION
T	±0.017 [0.43]	in [mm]	2.040 [51.82]
E	±0.017 [0.43]	in [mm]	1.950 [49.53]
I	±0.010 [0.25]	in [mm]	1.841 [46.76]
S'	±0.015 [0.38]	in [mm]	0.100 [2.54]
H	±0.010 [0.25]	in [mm]	0.412 [10.46]
OAH	±0.020 [0.51]	in [mm]	1.605 [40.77]
MAXIMUM OD	±0.017 [0.43]	in [mm]	2.195 [55.75]
PART WEIGHT	±1.50	g	16.30
MAX VOLUME	±5%	oz [cc]	1.86 [55]

STATIC TORQUE RECOMMENDATION
21-36 in-lbs
 THIS REQUIREMENT MAY VARY DEPENDING
 UPON BOTTLE MATERIAL, NECK FINISH, AND
 CAPPING EQUIPMENT

DRAWING TYPE : **CUSTOMER**

REPLACES DRAWINGS:
 J-7011

DIMENSIONS ENCLOSED IN ()
 INDICATE REFERENCE
 DIMENSIONS AND NO TOLERANCE
 LIMITS ARE ESTABLISHED

TOLERANCES UNLESS OTHERWISE SPECIFIED

DIMENSION (inches)	TOLERANCE	DIMENSION (mm)	TOLERANCE
0-0.787	±0.006	0-20	±0.152
0.788-1.181	±0.008	21-30	±0.203
1.182-2.756	±0.012	31-70	±0.305
2.757-3.937	±0.016	71-100	±0.406
3.938-5.096	±0.020	101-150	±0.508
5.097-7.874	±0.024	151-200	±0.610
7.875-9.843	±0.032	201-250	±0.813

ANGULAR TOLERANCE ± 2°

PROPRIETARY AND CONFIDENTIAL

THE CLOSURE DIMENSIONS
 DEPICTED ARE THOSE WHICH HAVE GENERALLY BEEN
 FOUND TO BE FUNCTIONAL BASED ON INDUSTRY
 EXPERIENCE BECAUSE OF VARIABILITY IN GLASS AND
 PLASTIC CONTAINER FINISHES, EACH CLOSURE/FINISH
 SYSTEM SHOULD BE INDIVIDUALLY EVALUATED AND
 TESTED TO ENSURE IT MEETS APPLICABLE
 PERFORMANCE CRITERIA. SEE QUALITY ASSURANCE
 SPECIFICATIONS FOR ADDITIONAL INFORMATION.

THE CARY COMPANY RESERVES THE RIGHT TO REVISE
 ANY OR ALL SPECIFICATIONS AND REQUIREMENTS.

The
CARY COMPANY
 Est. 1895

67WD36



THIRD ANGLE
 PROJECTION

DISTRIBUTION
 CODE
D

DRAWING NAME

**1oz 53 Double Wall
 ROUND JAR ASSEMBLY**

DRAWING NUMBER

CQA - 10515

MATERIAL

POLYPROPYLENE

MODEL NUMBER:

PM 10517 1oz 53mm DW Jar

DRAWN BY: JDM

JDM

11/27/2017

ENG APPR: JDM

JDM

2/15/2018

QA APPR: REL

REL

02/17/2018

SCALE

1:1

SHEET SIZE

8.5" X 11"

SHEET

1 of 2

REV NP

00.AA

DATE	REV	N/P	DESCRIPTION	ENG	DRWN
12/6/2017	00	AA	UPDATE DRAWING FORMAT AND ASSIGN NEW DRAWING NUNMBER. TOLERANCES UPDATED PER CCMA STANDARDS.	JDM	JDM

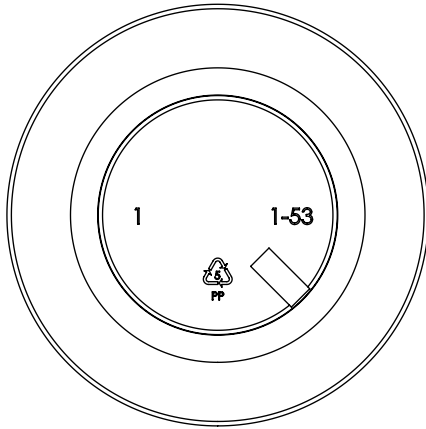
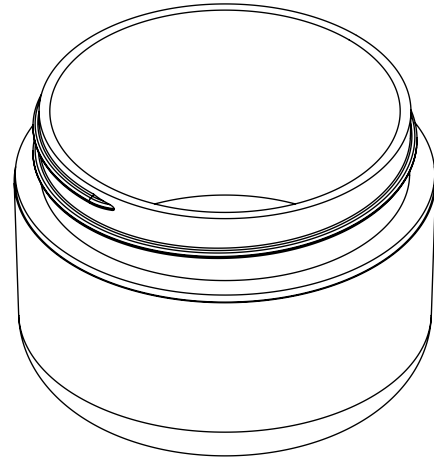
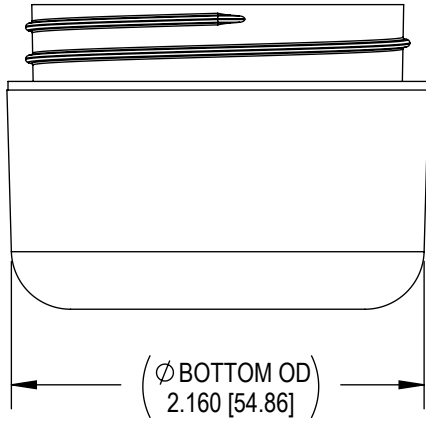

DRAWING TYPE : CUSTOMER

REFERENCES:
530104

DIMENSIONS ENCLOSED IN ()
INDICATE REFERENCE
DIMENSIONS AND NO TOLERANCE
LIMITS ARE ESTABLISHED

TOLERANCES UNLESS OTHERWISE SPECIFIED

DIMENSION (inches)	TOLERANCE	DIMENSION (mm)	TOLERANCE
0-0.787	±0.006	0-20	±0.152
0.788-1.181	±0.008	21-30	±0.203
1.182-2.756	±0.012	31-70	±0.305
2.757-3.937	±0.016	71-100	±0.406
3.938-5.096	±0.020	101-150	±0.508
5.097-7.874	±0.024	151-200	±0.610
7.875-9.843	±0.032	201-250	±0.813

ANGULAR TOLERANCE ± 2°

PROPRIETARY AND CONFIDENTIAL



SOLIDWORKS

DISTRIBUTION
CODE
D

DRAWING NAME
**1oz 53 Double Wall
ROUND JAR ASSEMBLY**

DRAWING NUMBER
CQA - 10515

MATERIAL
POLYPROPYLENE

MODEL NUMBER:
PM 10517 1oz 53mm DW Jar

DRAWN BY:	JDM	11/27/2017
ENG APPR.	JDM	2/15/2018
QA APPR.	REL	02/17/2018

SCALE	SHEET SIZE	SHEET	REV.NP
1:1	8.5" X 11"	2 of 2	00.AA

THE CLOSURE DIMENSIONS
DEPICTED ARE THOSE WHICH HAVE GENERALLY BEEN
FOUND TO BE FUNCTIONAL BASED ON INDUSTRY
EXPERIENCE BECAUSE OF VARIABILITY IN GLASS AND
PLASTIC CONTAINER FINISHES, EACH CLOSURE/FINISH
SYSTEM SHOULD BE INDIVIDUALLY EVALUATED AND
TESTED TO ENSURE IT MEETS APPLICABLE
PERFORMANCE CRITERIA. SEE QUALITY ASSURANCE
SPECIFICATIONS FOR ADDITIONAL INFORMATION.
THE CARY COMPANY RESERVES THE RIGHT TO REVISE
ANY OR ALL SPECIFICATIONS AND REQUIREMENTS.