

IF YOU...



MIX IT. FILL IT. PACK IT. SHIP IT.

WE HAVE A PRODUCT FOR YOU



Part #	67WPSP
Capacity	16 oz.
Color	Clear
Material	PS
Dimensions	3.374" Dia. x 3.86"H
Neck Finish	89-400
Neck Width	89mm
BPA Free	Yes
FDA Approved	Yes
Case Pack	140 ea.
Pallet Pack	3,500 ea. (25 Cases)



NOTE:

PROPRIETARY AND CONFIDENTIAL:

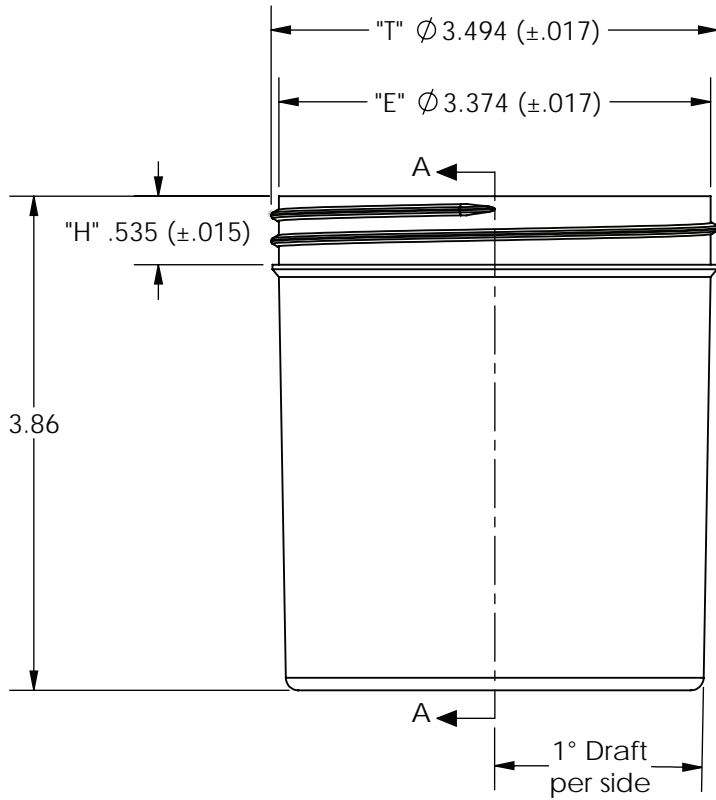

SECTION A-A

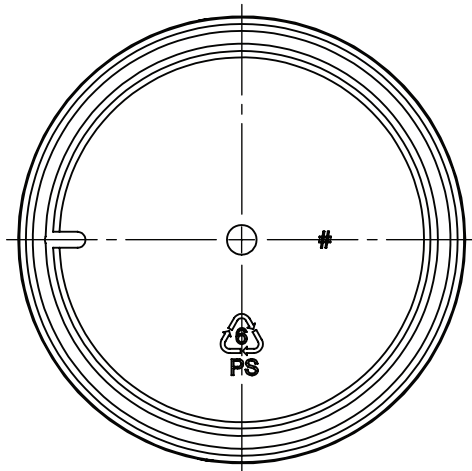
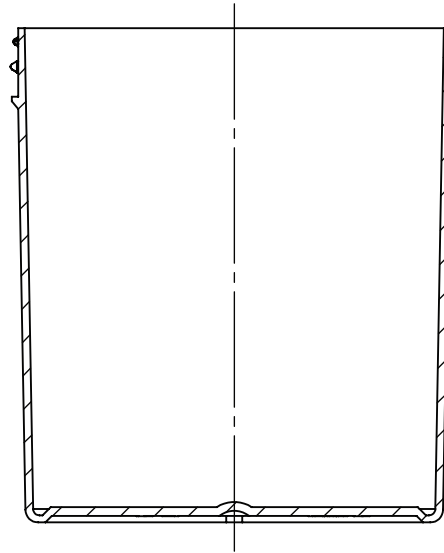

DRAWING NAME: PART DWG - JSS1689CS - MJ1006-009			
PART NAME: 16 oz 89 mm Straight Side Jar		PART #: JSS1689CS : MJ1006-009	
		2 0 1 2	BY: DATE:
		DRAWN	S.B. 4/17/2012
		CHECKED	S.B. 4/17/2012
		APPROVED	S.B. 4/17/2012
		DIMENSIONS ARE IN INCHES	
THREAD PITCH: 5 T.P.I.		# OF THREAD TURNS: 1-1/2 TURNS	TOLERANCES (UNLESS SPECIFIED) .00 = \pm .015 .000 = \pm .010
DRAFT ANGLE: 1° Degree		PROJECTED COSMETIC FILL: 425 (\pm 11) M L 14.4 (\pm .4) O Z	ANGULAR TOLERANCE \pm 1/2 DEGREE
GATE LOCATION: EXTERIOR - CENTER		PROJECTED OVERFLOW: 495 (\pm 11) M L 16.7 (\pm .4) O Z	THIRD ANGLE PROJECTION
MATERIAL: POLYSTYRENE		PART WEIGHT: 49.5 Grams (\pm 5%)	SHEET SCALE: FULL SHEET SIZE: A



Supplied By: **The Cary Company**
 Ph: 630-629-6600
 www.thecarycompany.com