

IF YOU...

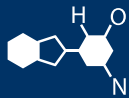

MIX IT. FILL IT. PACK IT. SHIP IT.

WE HAVE A **PRODUCT** FOR YOU

Part #68W16N

Plastic Decanters & Carafes

16 oz. Natural HDPE Plastic Carafe Bottle, 28mm 28-400



The
CARYCOMPANY
Est. 1895

STK016-1

NOTICE CONFIDENTIAL PROPERTY

SYM.	DATE	REVISIONS

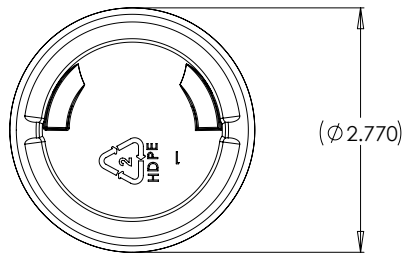
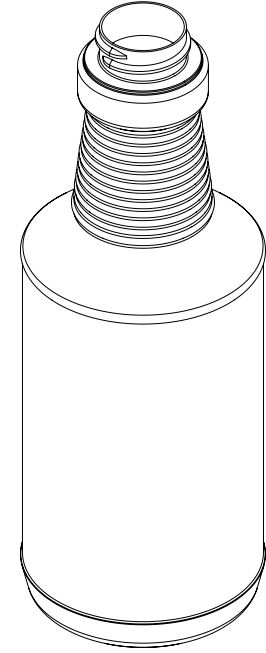
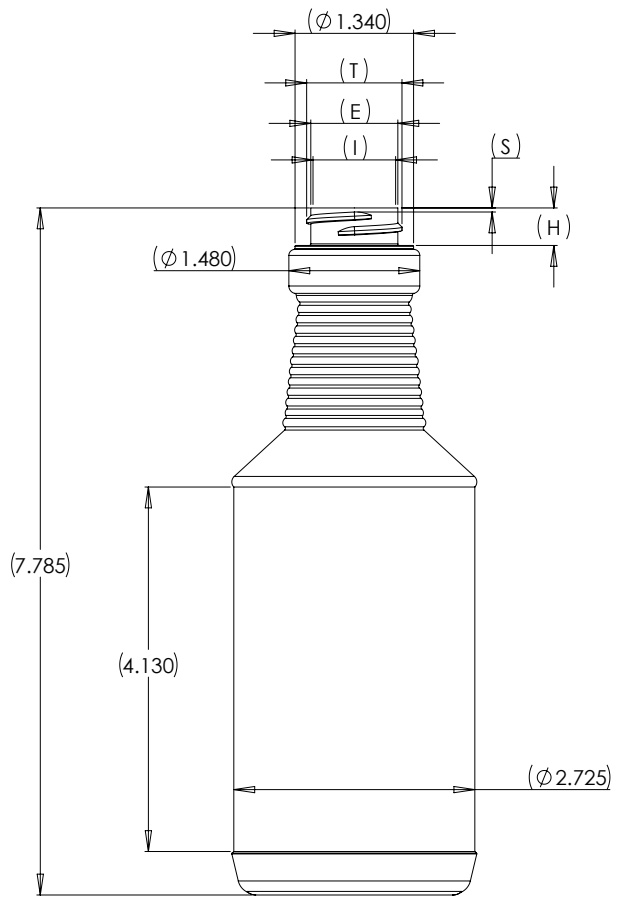

28-400 NECK FINISH		
SYM.	MAX.	MIN.
T	1.088	1.068
E	0.994	0.974
H	0.440	0.410
S	0.061	0.031
I	0.000	0.614
L	0.000	0.000

TOLERANCES	REVISIONS		
	NO.	DATE	BY
DECIMAL ±.000			
HEIGHT ±.050			
WIDTH&DEPTH ±.060			

16oz. Carafe			
DRAWN BY	MW	DATE	07.29.19
REDRAWN BY		DATE	000000
CHK'D BY		SCALE	1-1
MATERIAL		HDPE	
DRAWING NO.		6001-050	