

IF YOU...



MIX IT. FILL IT. PACK IT. SHIP IT.

WE HAVE A PRODUCT FOR YOU



Part #	68W25P
Neck Width	24mm
Neck Finish	24-400
Color	White
Material	PP



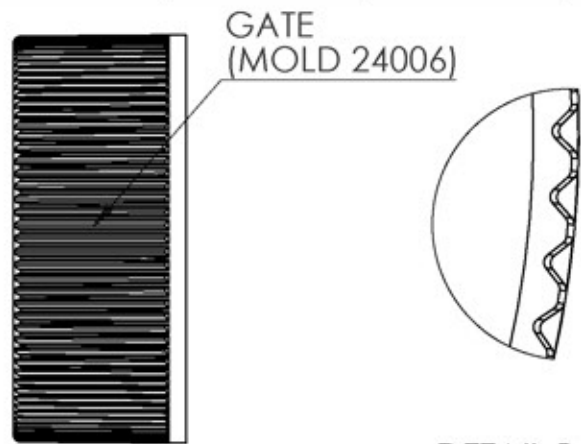
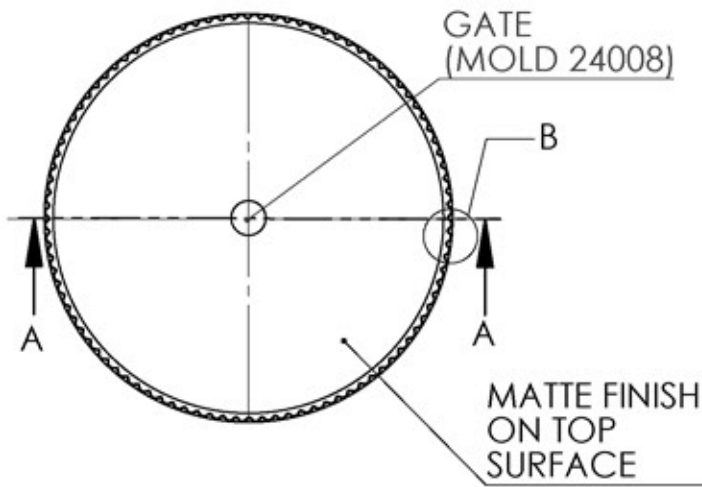

DETAIL B
SCALE 10 : 1
(96) EQUISPACED RIBS

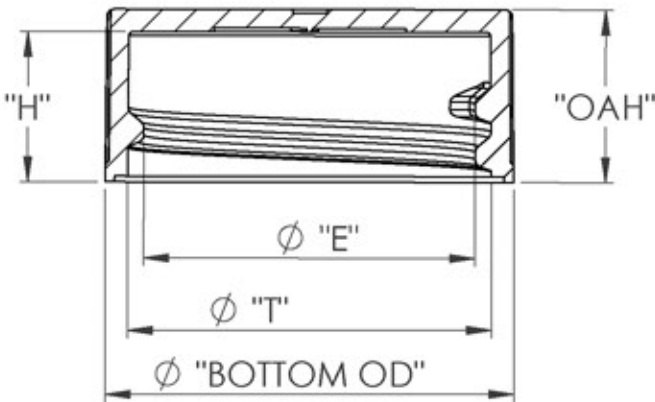

SECTION A-A
SCALE 2 : 1



SCALE 1 : 1

**THIS DRAWING SUPERSEDES
DRAWING C-5005-A**

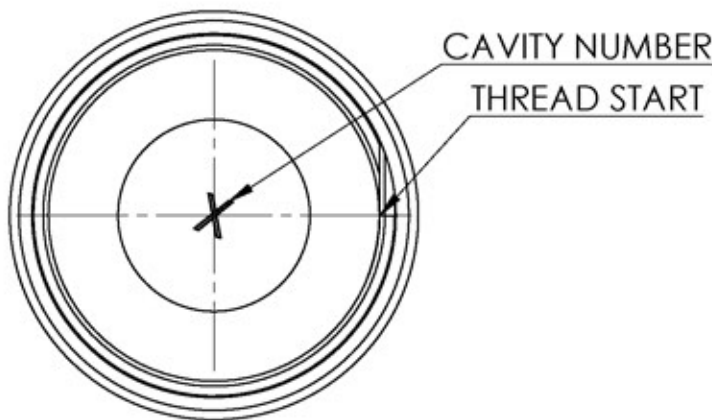

8 THREADS PER INCH, 0.125 PITCH
380° FULL DEPTH THREAD

	TOLERANCE	UNITS	
T	±0.008 [0.20]	in [mm]	0.949 [24.10]
E	±0.008 [0.20]	in [mm]	0.865 [21.97]
H	±0.007 [0.18]	in [mm]	0.392 [9.96]
OAH	±0.009 [0.23]	in [mm]	0.446 [11.33]
BOTTOM OD	±0.008 [0.20]	in [mm]	1.063 [27.00]
PART WEIGHT	±0.18	g	1.58

STATIC TORQUE RECOMMENDATION
10-18 in-lbs

THIS REQUIREMENT MAY VARY
DEPENDING UPON BOTTLE MATERIAL,
NECK FINISH, AND CAPPING EQUIPMENT

DRAWING TYPE : CUSTOMER

DIMENSIONS ENCLOSED IN () INDICATE REFERENCE
DIMENSIONS AND NO TOLERANCE LIMITS ARE ESTABLISHED

TOLERANCES UNLESS OTHERWISE SPECIFIED

DIMENSION (inches)	TOLERANCE	DIMENSION (mm)	TOLERANCE
0-0.787	±0.006	0-20	±0.152
0.788-1.181	±0.008	21-30	±0.203
1.182-2.756	±0.012	31-70	±0.305
2.757-3.937	±0.016	71-100	±0.406
3.938-5.096	±0.020	101-150	±0.508
5.097-7.874	±0.024	151-200	±0.610
7.875-9.843	±0.032	201-250	±0.813

ANGULAR TOLERANCE ± 2°

The
CARY COMPANY
Est. 1895

THIRD ANGLE PROJECTION SOLIDWORKS	DISTRIBUTION CODE D	DRAWING NAME 24mm-400 "RMX" CLOSURE
DRAWN BY: CDB	12/9/14	DRAWING NUMBER
QA APPR:		MATERIAL POLYPROPYLENE
		MODEL NUMBER: 10093
		SCALE SHEET SIZE SHEET REV N/P 21 & NOTED 8½ x 11 1 of 3 00 AB

Recommended Neck Finish

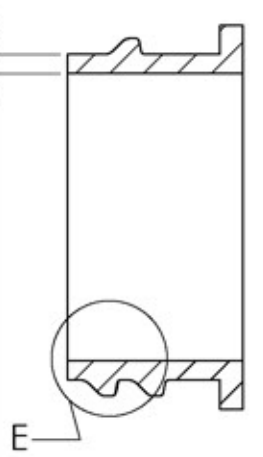
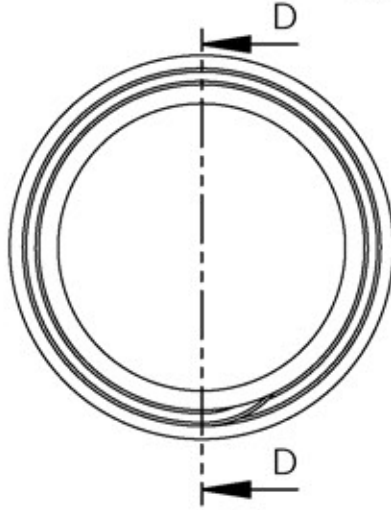

SECTION D-D
SCALE 2 : 1

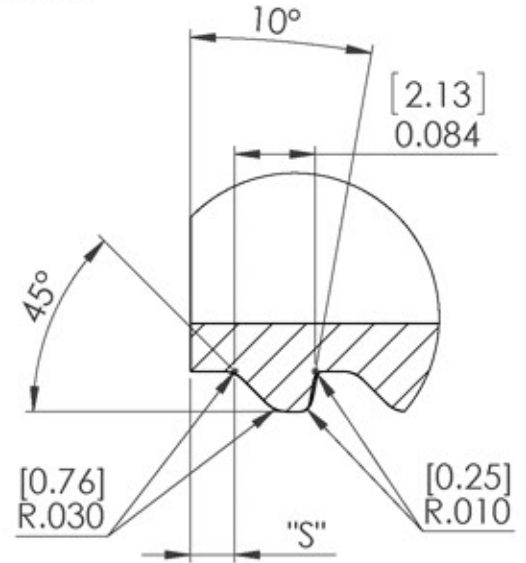

DETAIL E
SCALE 5 : 1

THREAD DETAIL

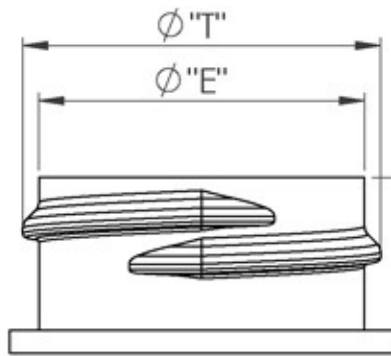

[10.08]
0.397

MINIMUM
"H"

(WITHOUT LINER)

0.050 [1.27] MINIMUM RECOMMENDED
FLAT FOR PROPER INDUCTION SEAL

	TOLERANCE	UNITS	
E	±0.008 [0.20]	in (mm)	0.848 [21.54]
T	±0.008 [0.20]	in (mm)	0.932 [23.67]
H		in (mm)	
I		in (mm)	
S	±0.015 [0.38]	in (mm)	0.046 [1.17]
TPI			8
PITCH		in (mm)	0.125 [3.18]

DRAWING TYPE : CUSTOMER

DIMENSIONS ENCLOSED IN () INDICATE REFERENCE DIMENSIONS AND NO TOLERANCE LIMITS ARE ESTABLISHED

TOLERANCES UNLESS OTHERWISE SPECIFIED

DIMENSION (inches)	TOLERANCE	DIMENSION (mm)	TOLERANCE
0-0.787	±0.006	0-20	±0.152
0.788-1.181	±0.008	21-30	±0.203
1.182-2.756	±0.012	31-70	±0.305
2.757-3.937	±0.016	71-100	±0.406
3.938-5.096	±0.020	101-150	±0.508
5.097-7.874	±0.024	151-200	±0.610
7.875-9.843	±0.032	201-250	±0.813

ANGULAR TOLERANCE ± 2°

The
CARY COMPANY
Est. 1895

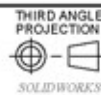

DISTRIBUTION CODE

D

DRAWING NAME

24mm-400 "RMX" CLOSURE

DRAWING NUMBER

DRAWN BY: REFER TO PAGE 1

QA APPR: REFER TO PAGE 1

MATERIAL

SCALE	SHEET SIZE	SHEET	REV	N/P
2:1	8 1/2 x 11	3 of 3	00	AB