

# IF YOU...



MIX IT. FILL IT. PACK IT. SHIP IT.

# WE HAVE A PRODUCT FOR YOU



Part #	68W3SS
Neck Width	38mm
Neck Finish	38-400
Cap Liner	PS22 .020 Pressure Seal Polystyrene Foam Printed Liner
Feature	Push Down & Turn - Embossed
Color	White
Material	PP
Case Pack	1,500 ea.
Pallet Pack	52,500 ea. (35 Cases)
Case Weight	26 lbs.
FDA Approved	Yes
Industries	Automotive, Household Chemicals, Nutraceuticals, Pharmaceutical
Note	**Pressure sensitive liners are not considered a form of tamper evident seal.

REVISIONS			
REV.	DATE	APPROVAL	DESCRIPTION
1	1-14-99	G.G.	"B" .670
2	1-14-99	G.G.	"B" WITHOUT EMBOSSED .655
3	9-13-02	G.G.	H dimension- .375



Supplied By: **The Cary Company**  
 Ph: 630-629-6600  
 www.thecarycompany.com

TWO PIECE CAP  
 ASSEMBLED

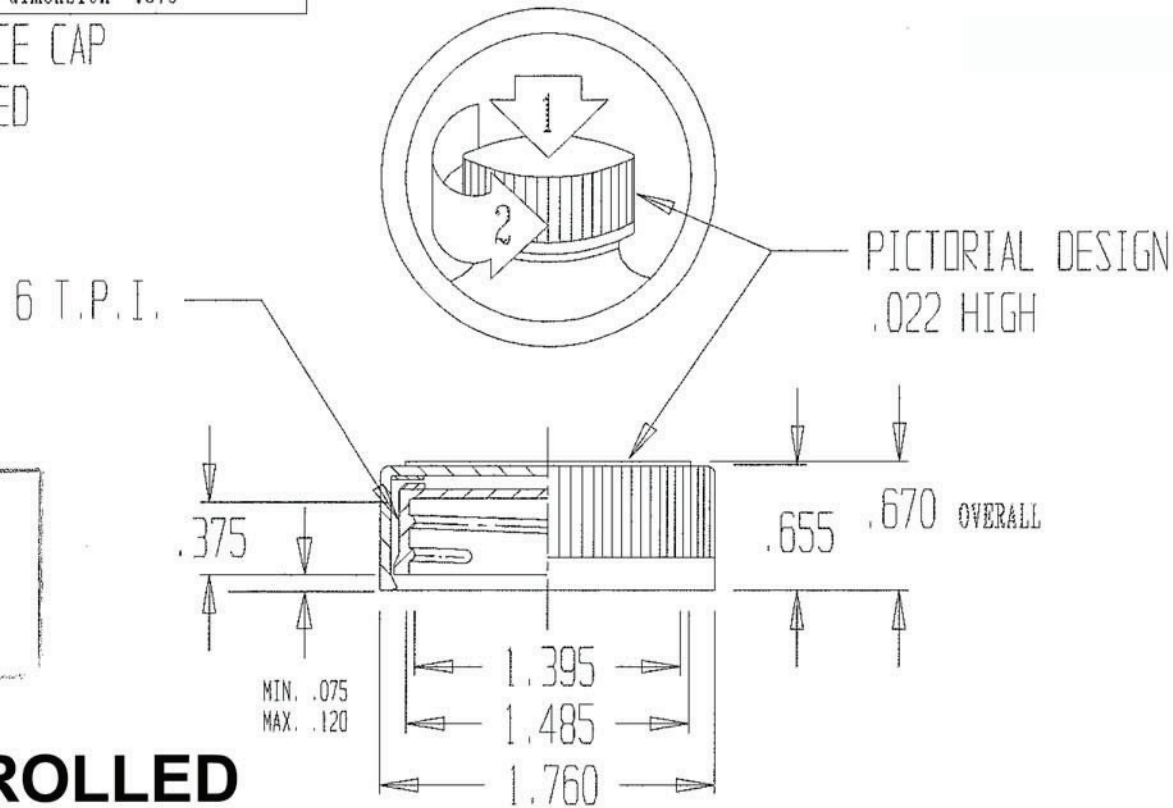

**UNCONTROLLED**

"T"	"E"	"H"	"A"	"B"
1.485	1.395	.375	1.760	.670
MATERIAL: POLYPROPYLENE				
WEIGHT: 7 GRAMS +/- 1.5 grams				

"CRC" 38MM-400 CAP	
<b>68W3SS, 68WV38</b>	
TOLERANCE: +/- .010	DRAWN BY: P.D.T.
SCALE: FULL	DATE: 1-14-99
DRAWING NO. C-8019	