

IF YOU...

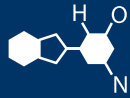

MIX IT. FILL IT. PACK IT. SHIP IT.

WE HAVE A PRODUCT FOR YOU

Part # 68W4WH

4 oz. Clear PET Plastic Tamper Evident WH
Square Bottle, 38mm 358DBJ



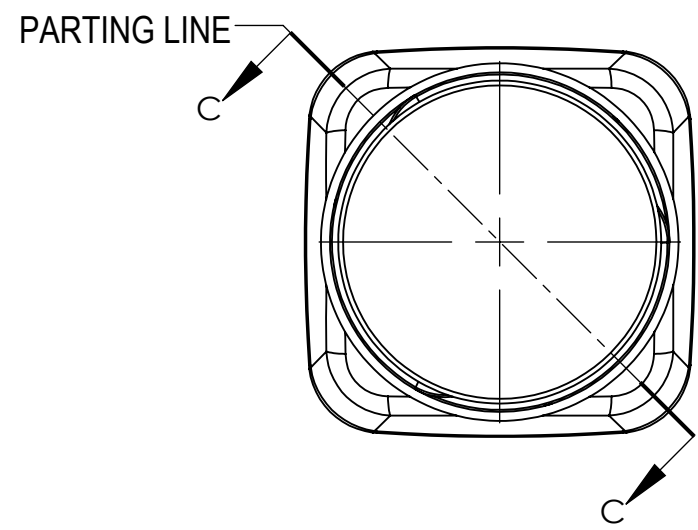

38MM DBJ
REF. PORTOLA
N358015C

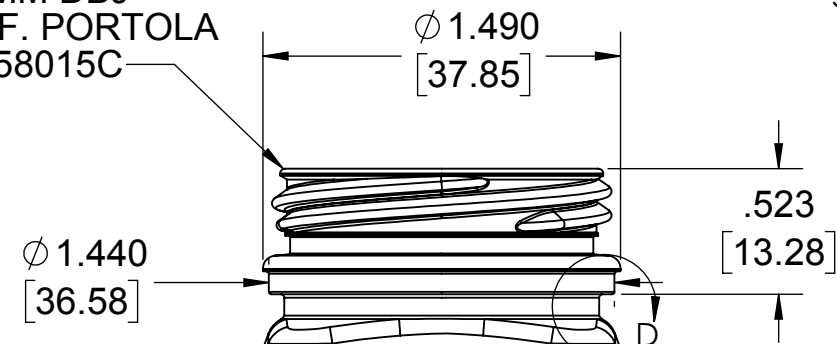

DETAIL D
SCALE 4:1

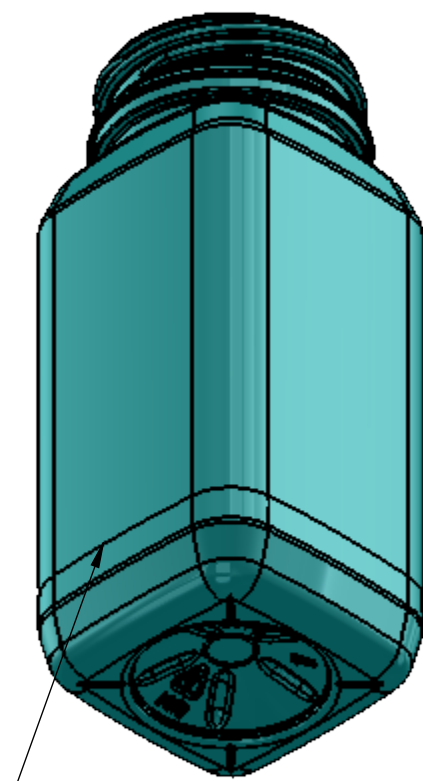
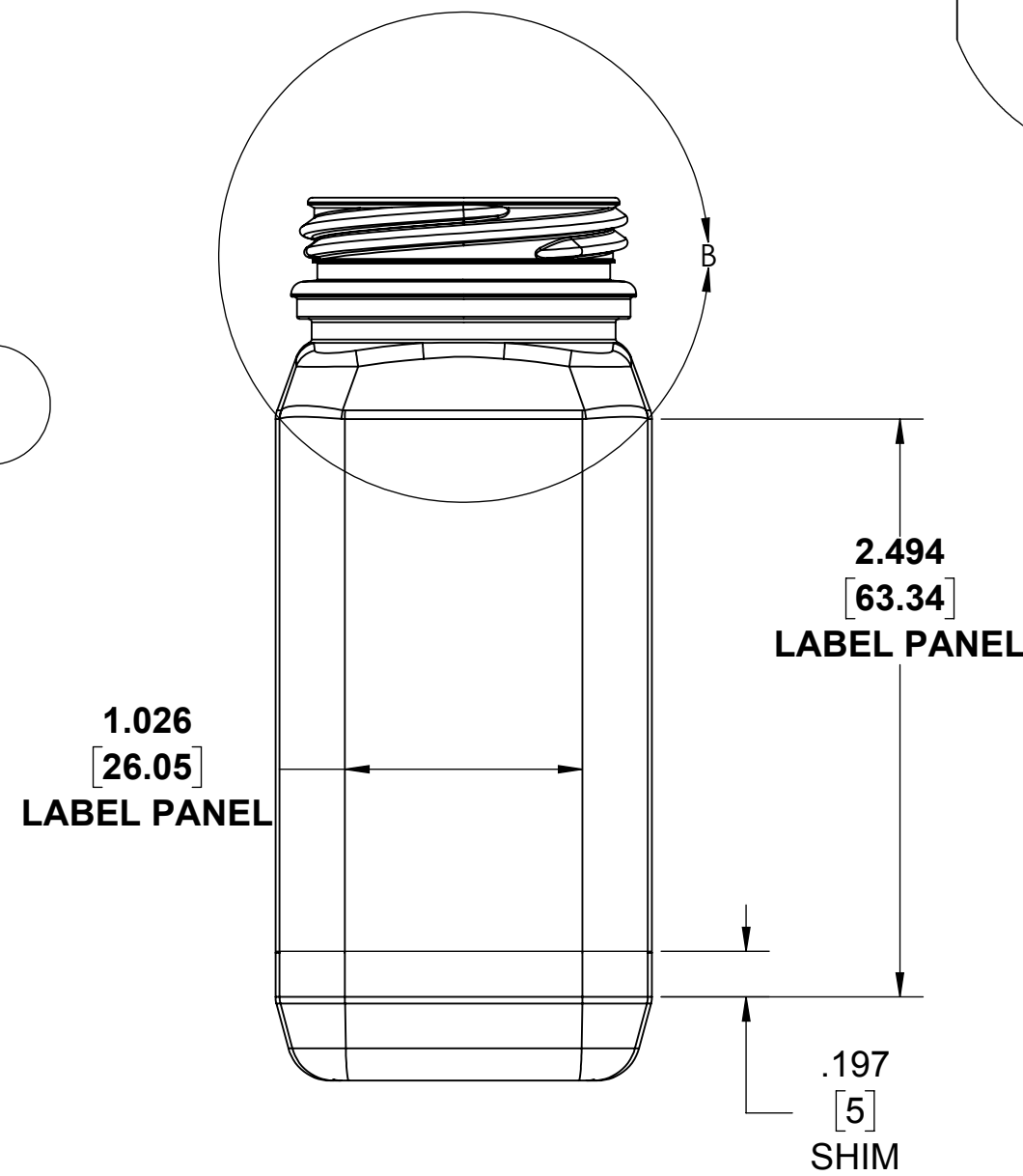
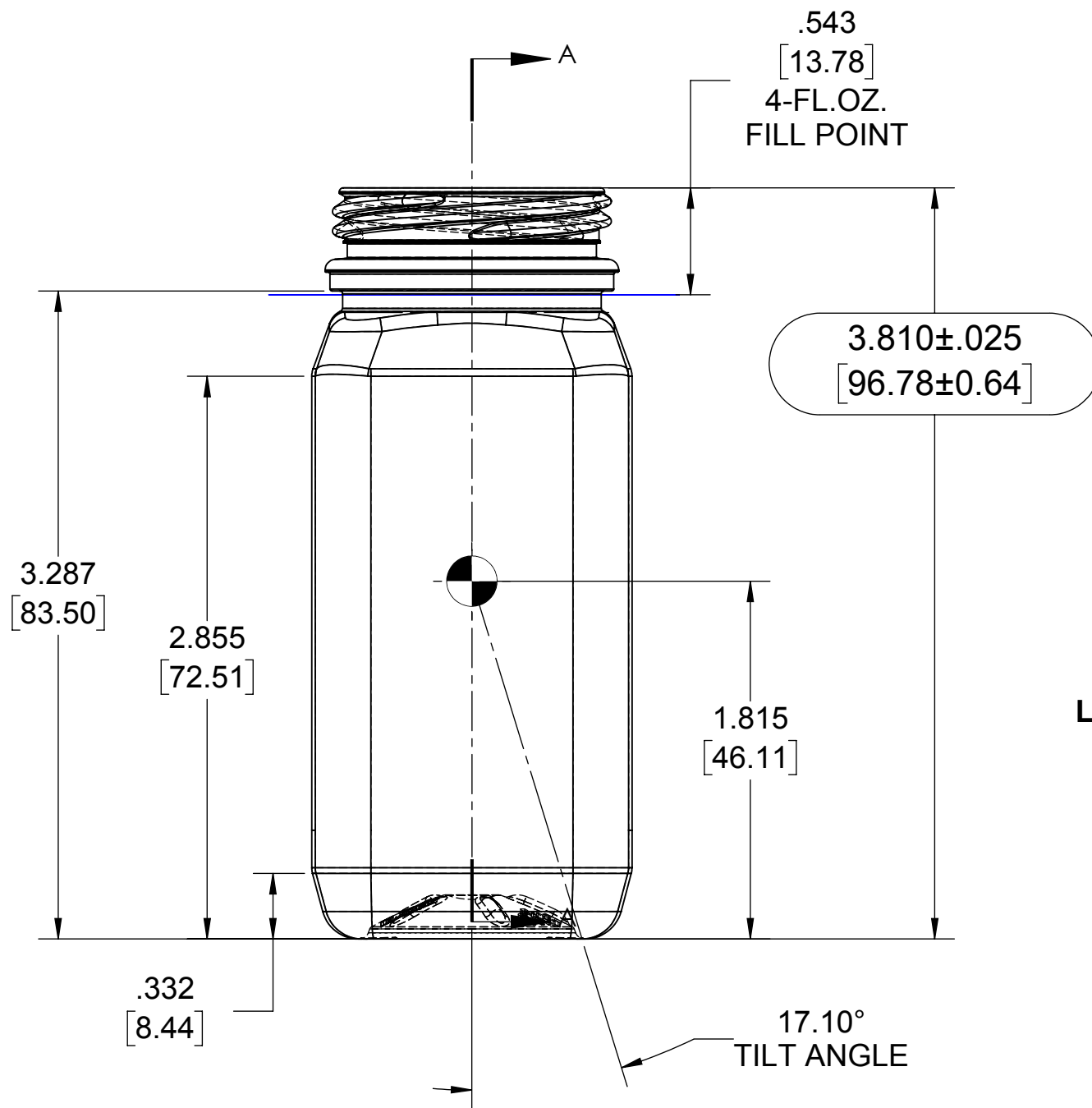
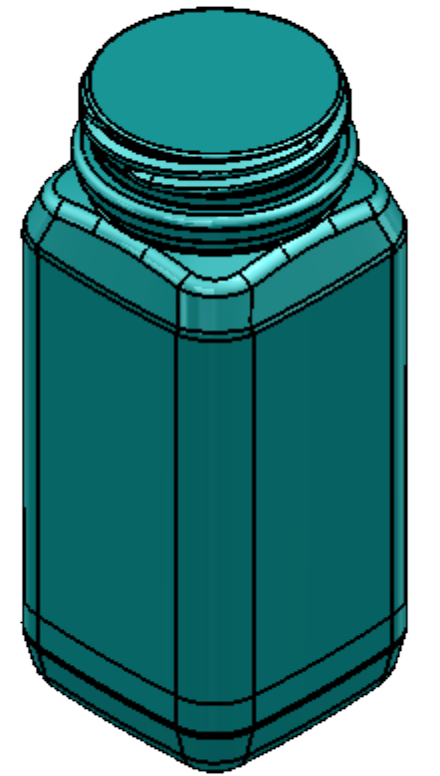
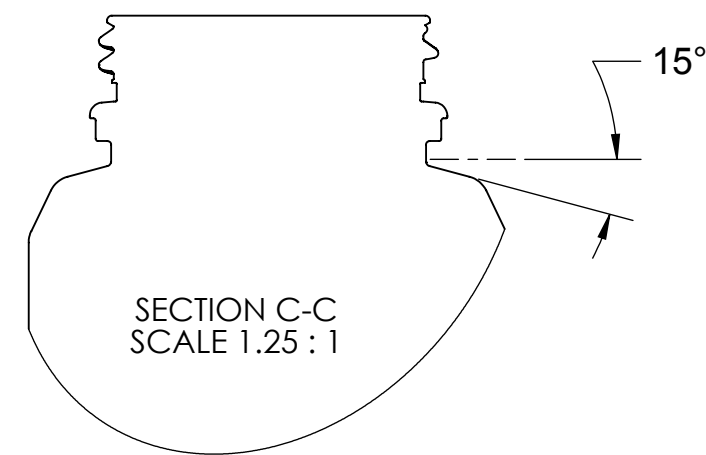
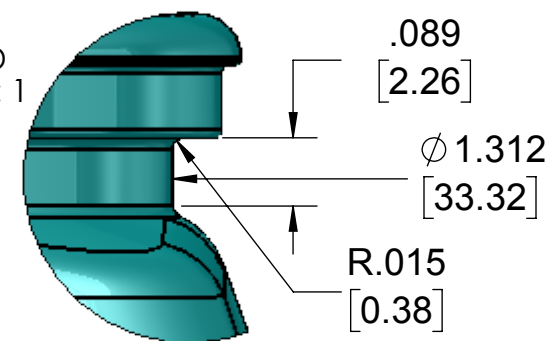

LABEL PANEL PERIMETER
5.847 INCHES

STANDARD MANUFACTURING SPECIFICATIONS STATEMENT
FOR BOTTLES 72 HOURS AFTER MANUFACTURE WHEN STORED AT ROOM
TEMPERATURE AND 50% R.H.

- ALL DRAWINGS ARE DUAL DIMENSIONED (INCHES AND MILLIMETERS)
- THE FOLLOWING TOLERANCES APPLY FOR OVERALL HEIGHT, MAJOR DIAMETER, AND LABEL PANEL(EXCEPT WHERE NOTED)
HEIGHT..... ±0.5% OF STATED DIMENSIONS
DIAMETERS ±1.0% OF STATED DIMENSIONS
- THE FOLLOWING CAPACITY TOLERANCES APPLY (EXCEPT WHERE NOTED) FOR COLD FILLED CONTAINERS **NOMINAL** CAPACITY
<=300mlAVERAGE +6ml - 0.0
>300ml TO <=1000ml.....AVERAGE +1.6% - 0.0
>1000ml TO <2000ml.....AVERAGE +1.2% - 0.0
>=2000ml.....AVERAGE +1.0% - 0.0
- DIMENSIONS AND WEIGHT ARE SUBJECT TO CHANGE WITH FINAL VOLUMETRIC CALCULATIONS.
- FINAL VOLUME TOLERANCE TO BE DEFINED BY MFG. DATA.

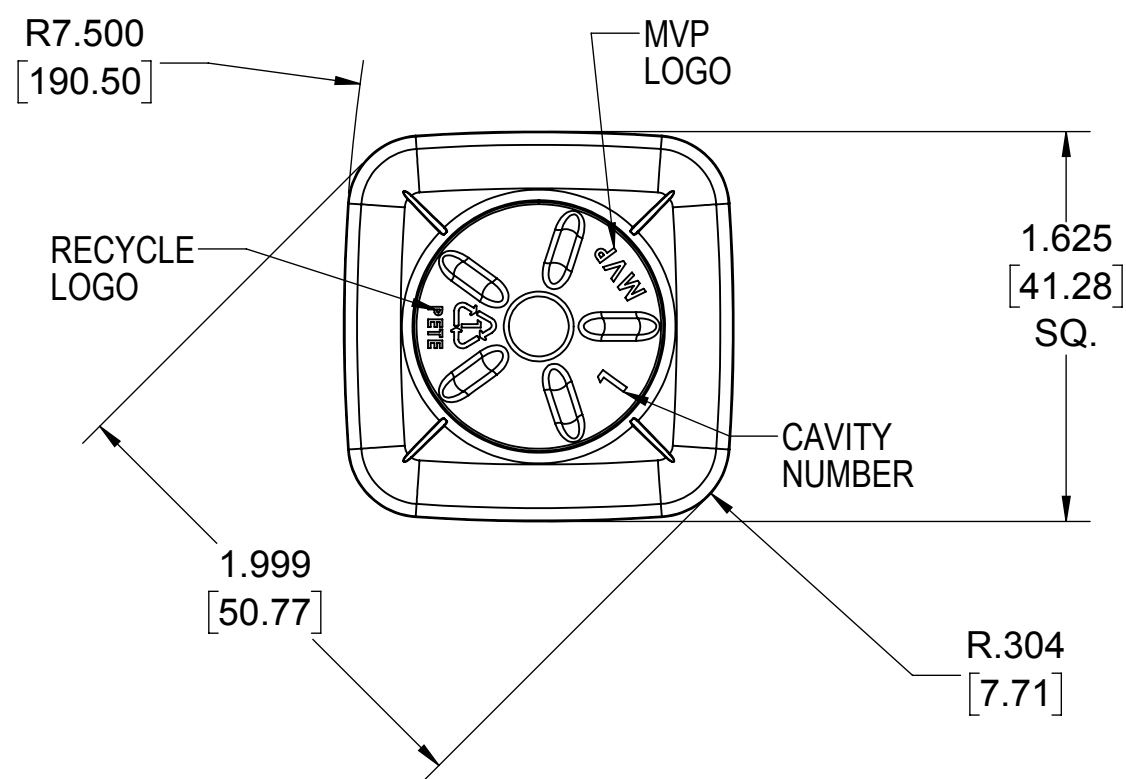

FILLPOINT VOLUME= 118.3ml / 4.0 fl oz.		MATERIAL	PET
OVERFLOW VOLUME = 127.39ml / 4.3 fl oz.		FINISH	PORTOLA DBJ
PROPOSED PREFORM 16.25g 1543-13-PD-B-00			
REF. 3 D MODEL FILE 2373-16-BD-C-00			
DRAWN	D.CONNOR	DATE	12-15-15
CHECKED			
ENG APPR.			
MFG APPR.			
DO NOT SCALE DRAWING			
COMMENTS:			
PROJECT # 16-125		4 oz WH SQ 16.25G DBJ	
		SIZE DWG. NO.	REV
		C	2373-16-BD-C-00 -
		SCALE: 1:1	SHEET 1 OF 3