

IF YOU...

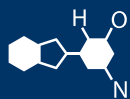

MIX IT. FILL IT. PACK IT. SHIP IT.

WE HAVE A **PRODUCT** FOR YOU

Part #68WWFS

Plastic F-Style Bottles

1 Gallon White HDPE Plastic F-Style Bottle, 38mm 38-400, 140 Grams



The
CARYCOMPANY
Est. 1895

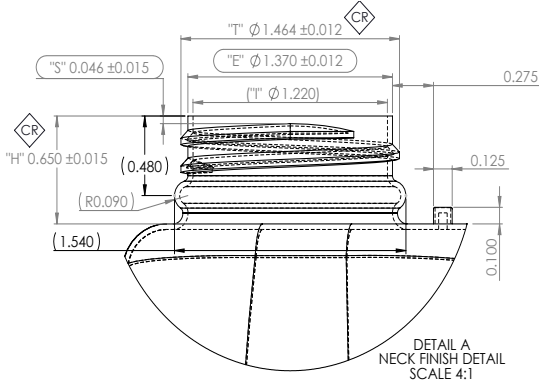

DETAIL A
NECK FINISH DETAIL
SCALE 4:1
M38-400 FINISH
SPECIAL "H"
6 T.P.I
1.25 FULL THREAD TURNS

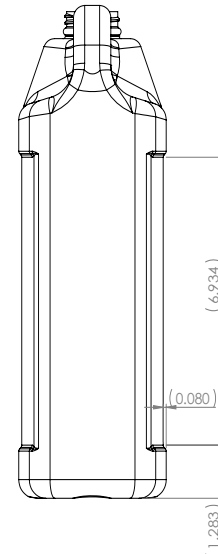
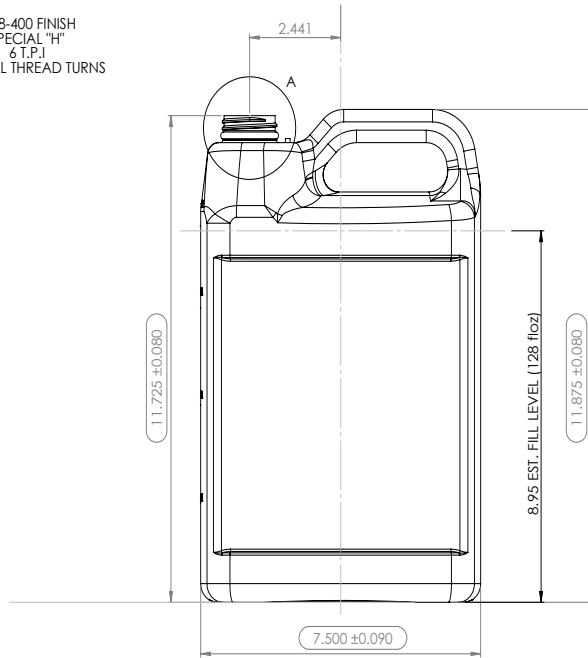
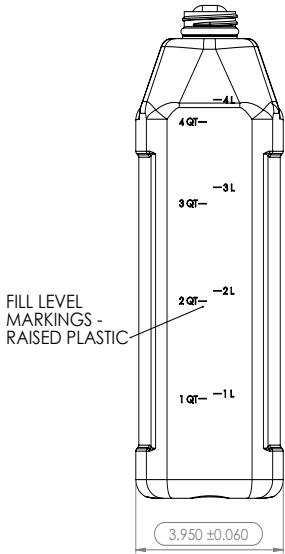
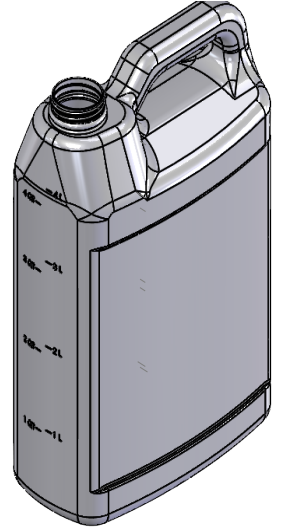
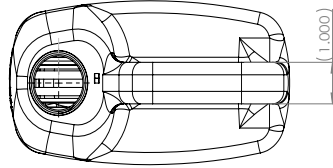

1. DIMENSIONS OR NOTES MARKED WITH A DENOTE CRITICAL CHARACTERISTICS TO BE MONITORED DURING PRODUCTION.
2. DIMENSIONS OR NOTES MARKED WITH A DENOTE CHARACTERISTICS TO BE MONITORED DURING PRODUCTION QUALIFICATION ONLY.
3. ALL DIAMETER DIMENSIONS MARKED WITH OR SHALL BE DETERMINED BY AVERAGING THE MEASUREMENTS AT PARTING LINE AND 90 DEGREES FROM PARTING LINE.
4. REFERENCE ONLY DIMENSIONS CONTAINED IN [].
5. MINIMUM CONTAINER WALL THICKNESS .015"
6. CONTAINER TOP LOAD REQUIREMENT TO BE 180 LBS. MINIMUM AT 1/4" DEFLECTION.
7. MATERIAL HDPE
8. TARGET WEIGHT 140.0 GRAMS.
9. OVERFLOW CAPACITY 145 +/- 1.8 fl.oz.
10. MEASUREMENTS TAKEN 24 HOURS AFTER MOLDING.

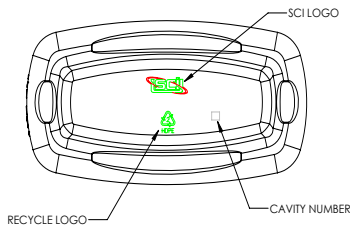

REV	DESCRIPTION	BY	DATE	DESCRIPTION	PRODUCT DRAWING
C	ADDED 4QT & 4L LEVEL MARKINGS	ZMF	8/30/23		
B	UPDATED CAPACITY TO REFLECT ACTUAL	ZMF	5/1/17		
A	ADDED "T" DIM REFERENCE	ZMF	4/7/16	TITLE: 1 GALLON F-STYLE	
REV	DESCRIPTION	BY	DATE	DESCRIPTION	PRODUCT DRAWING
DRAWN BY	DATE	CHECKED BY	DATE	DRWG. NO.	260PD
ZMF	3/8/16			SIZE C	SCALE 1:2 SHEET 1 OF 1 REV. C