

IF YOU...



MIX IT. FILL IT. PACK IT. SHIP IT.

WE HAVE A PRODUCT FOR YOU



Part #	99G020
Color	Aluminum
Material	Aluminum
Country of Manufacture	United States
Model	ASD-2448-PR6
Weight	59 lbs.
Load Capacity	3,000 lbs.
Wheel Type	6" X 2" Phenolic
Dimensions	24" x 48"
Note	*Note: Casters shown on the top right are the actual casters this platform truck includes.

ALUMINUM PLATFORM TRUCKS

Features:

- Aluminum is corrosion resistant and maintains clean appearance.
- Strong enough to handle up to 3,000 lbs (depending upon caster selection).
- Lightweight aluminum allows for easy maneuverability.
- Corner sockets at both ends allow handles to be used on either or both ends of truck.
- For truck platform height add 2.5" to caster height.
- Handle included.
- Bolt on casters. (Casters sold separately)

ASD - ALUMINUM SMOOTH DECK

- Smooth surface that is easy to keep clean.
- Solid one piece platform surface construction.

Model: ASD-2448
 Platform: 24" x 48"
 Weight: 33 lbs

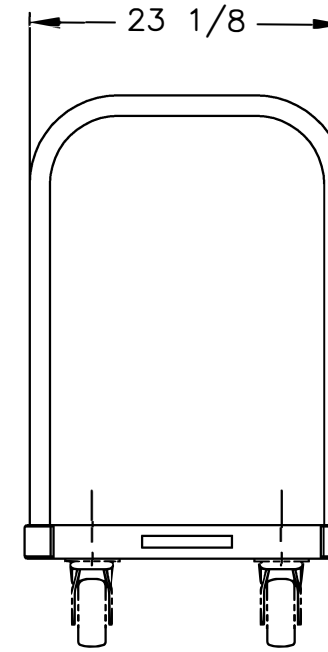
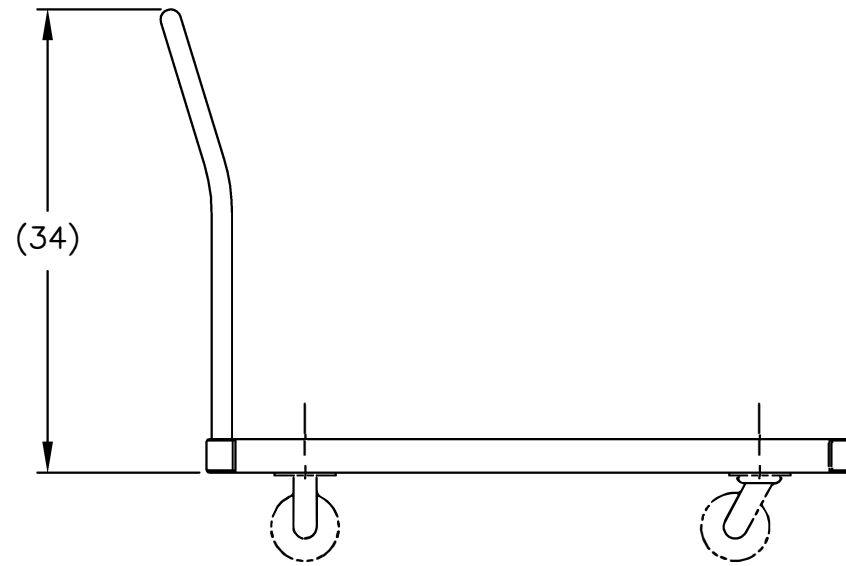
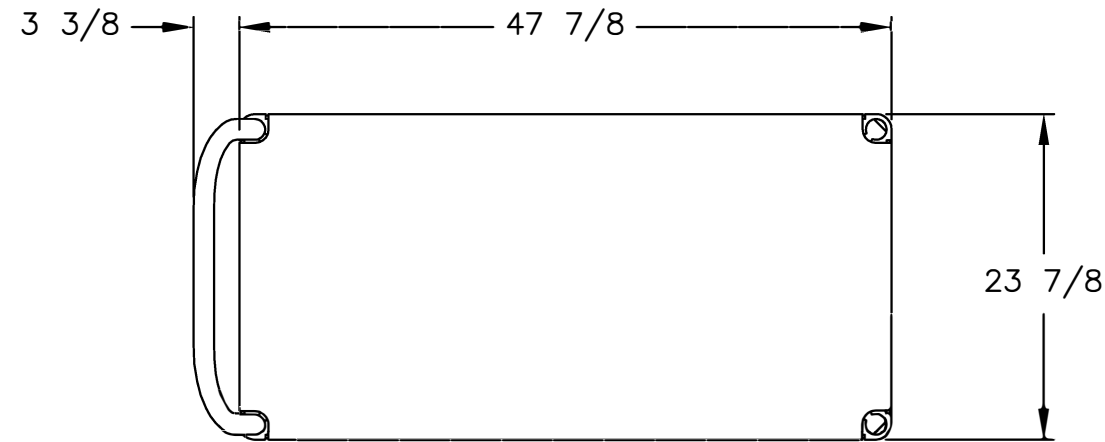

REPLACEMENT PARTS LIST

052574	24" PUSH HANDLE
052849	24" PUSH HANDLE W/CROSSBRACE
250022	SET: CORNER BUMPERS
250023	SET: PERIMETER BUMPERS
CASTER SETS (OPTION)	
250046	SR-5A POLYOLEFIN, 5 x 1.5"
250047	SR-5 POLYOLEFIN, 5 x 2"
240049	SR-6 POLYOLEFIN, 6 x 2"
250052	PR-6 PHENOLIC, 6" x 2"
250056	PR-8 PHENOLIC, 8" x 2"
250250	PN-8 PNEUMATIC, 8" x 2.5"
250050	MR-6 MOLDON RUBBER, 6" x 2"
250053	MR-8 MOLDON RUBBER, 8" x 2"
250051	MP-6 MOLDON POLYURETHANE, 6" x 2"
250055	MP-8 MOLDON POLYURETHANE, 8" x 2"

PRINT ISSUED
 OCT. 27, 2006



REV.	ECN & DATE	APP	PART NAME		DRAWN: SKH 7-29-94	
			ASD-2448		CHECKED:	
			TOLERANCE UNLESS OTHERWISE SPECIFIED		APP. ENGR.	
			FRACTION	3 PLACE DECIMAL	2 PLACE DECIMAL	SCALE: 1" = 14"
			± 1/64	± .005	± .01	B- 350028
			ANGULAR ± 1-1/2'	SHEET 1	OF 1	
BREAK ALL SHARP EDGES AND REMOVE ALL BURRS						