

IF YOU...

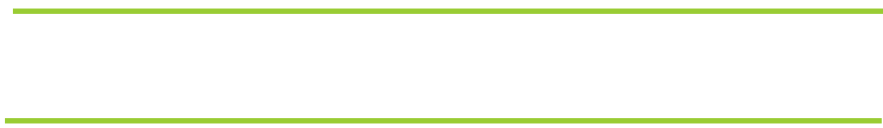

MIX IT. FILL IT. PACK IT. SHIP IT.

WE HAVE A PRODUCT FOR YOU



Part #	99G038
Color	Aluminum
Material	Aluminum
Country of Manufacture	United States
Model	ASD-3060-MR6
Weight	70 lbs.
Load Capacity	2,000 lbs.
Wheel Type	6" X 2" Moldon Rubber
Dimensions	30" x 60"
Note	*Note: Casters shown on the top right are the actual casters this platform truck includes.



ALUMINUM PLATFORM TRUCKS

Features:

- Aluminum is corrosion resistant and maintains clean appearance.
- Strong enough to handle up to 3,000 lbs (depending upon caster selection).
- Lightweight aluminum allows for easy maneuverability.
- Corner sockets at both ends allow handles to be used on either or both ends of truck.
- For truck platform height add 2.5" to caster height.
- Handle included.
- Bolt on casters. (Casters sold separately)

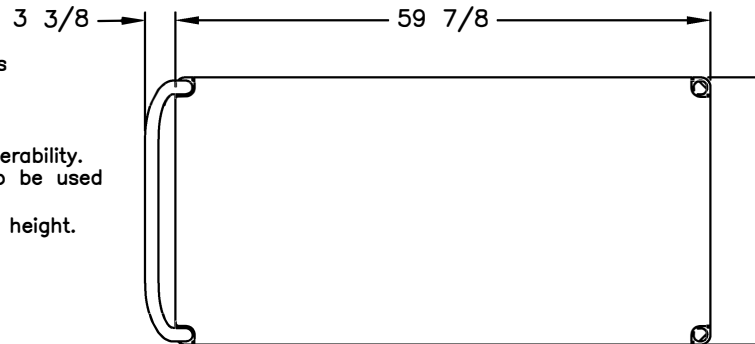

ASD - ALUMINUM SMOOTH DECK

- Smooth surface that is easy to keep clean.
- Solid one piece platform surface construction.

Model: ASD-3060
 Platform: 30" x 60"
 Weight: 44 lbs

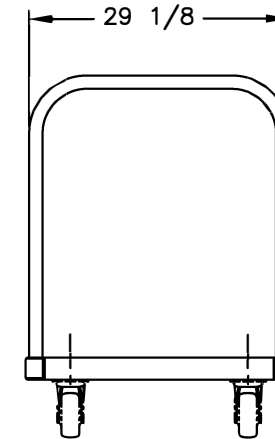
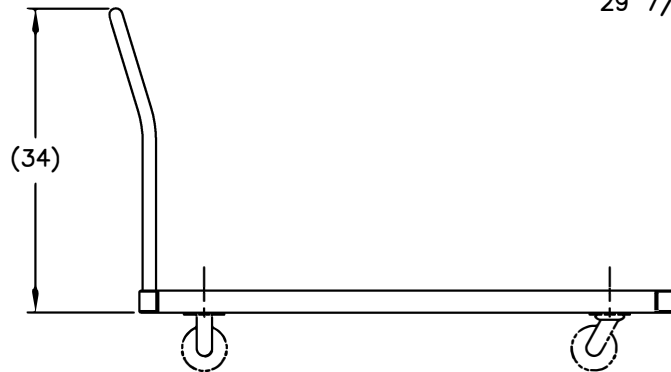
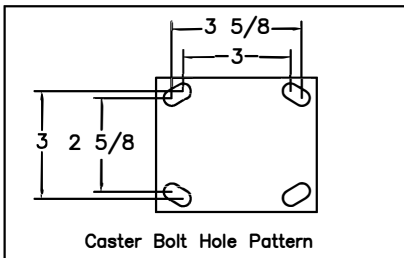

REPLACEMENT PARTS LIST

ITEM	P/N	DESCRIPTION	QTY
1	052575	30" PUSH HANDLE	1
2	052850	30" PUSH HANDLE W/CROSSBRACE	1
3	250022	SET: CORNER BUMPERS	1
4	250023	SET: PERIMETER BUMPERS	1
CASTER SET OPTIONS (INCLUDE 2 SWIVEL/2 RIGID)			
5	250046	SR-5A POLYOLEFIN, 5" x 1.5"	1
6	250047	SR-5 POLYOLEFIN, 5" x 2"	1
7	240049	SR-6 POLYOLEFIN, 6" x 2"	1
8	250052	PR-6 PHENOLIC, 6" x 2"	1
9	250056	PR-8 PHENOLIC, 8" x 2"	1
10	250250	PN-8 PNEUMATIC, 8" x 2.5"	1
11	250050	MR-6 MOLDON RUBBER, 6" x 2"	1
12	250053	MR-8 MOLDON RUBBER, 8" x 2"	1
13	250051	MP-6 MOLDON POLYURETHANE, 6" x 2"	1
14	250055	MP-8 MOLDON POLYURETHANE, 8" x 2"	1

PRINT ISSUED

APR. 26, 2018

The **CARY COMPANY**
 Est. 1895

REVISIONS ECN & DATE APP	PART NAME		DRAWN: SKH 7-29-94	
	ASD-3060		CHECKED:	
	TOLERANCE UNLESS OTHERWISE SPECIFIED		APP. ENGR.	
	FRACTION	3 PLACE DECIMAL	2 PLACE DECIMAL	SCALE: 1" = 14"
± 1/64	± .005	± .01		
ANGULAR ± 1-1/2°	SHEET 1	OF 1	B- 350031	
BREAK ALL SHARP EDGES AND REMOVE ALL BURRS				REV