

IF YOU...



MIX IT. FILL IT. PACK IT. SHIP IT.

WE HAVE A PRODUCT FOR YOU



24" x 36" Aluminum Platform Truck, Treadplate,
6" x 2" Polyurethane Casters, 3,000 lb. Capacity

Product Category: Aluminum Tread Platform Trucks

Part #	99G069
Color	Aluminum
Material	Aluminum
Country of Manufacture	United States
Model	ATP-2436-MP6
Weight	56 lbs.
Load Capacity	3000 lbs.
Wheel Type	6" x 2" Moldon Polyurethane
Dimensions	24" x 36"
Note	Casters shown on top right are the actual casters this platform truck includes.

ALUMINUM PLATFORM TRUCKS

Features:

- Aluminum is corrosion resistant and maintains clean appearance.
- Strong enough to handle up to 3,000 lbs (depending upon caster selection).
- Lightweight aluminum allows for easy maneuverability.
- Corner sockets at both ends allow handles to be used on either or both ends of truck.
- For truck platform height add 2.5" to caster height.
- Handle included.
- Bolt on casters. (Casters sold separately)

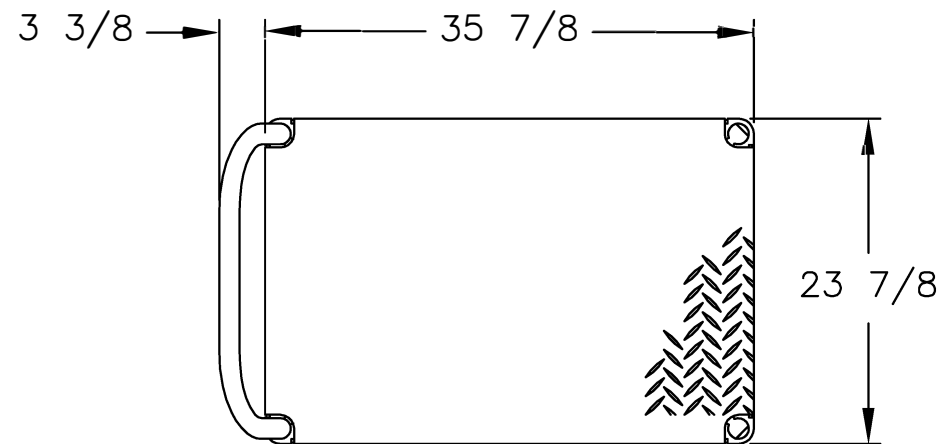

REPLACEMENT PARTS LIST

052574	24" PUSH HANDLE
052849	24" PUSH HANDLE W/CROSSBRACE
250022	SET: CORNER BUMPERS
250023	SET: PERIMETER BUMPERS

CASTER SETS (OPTION)

250046	SR-5A POLYOLEFIN, 5" x 1.5"
250047	SR-5 POLYOLEFIN, 5" x 2"
240049	SR-6 POLYOLEFIN, 6" x 2"
250052	PR-6 PHENOLIC, 6" x 2"
250056	PR-8 PHENOLIC, 8" x 2"
250250	PN-8 PNEUMATIC, 8" x 2.5"
250050	MR-6 MOLDON RUBBER, 6" x 2"
250053	MR-8 MOLDON RUBBER, 8" x 2"
250051	MP-6 MOLDON POLYURETHANE, 6" x 2"
250055	MP-8 MOLDON POLYURETHANE, 8" x 2"

ATP - ALUMINUM TREADPLATE MODEL

- Slip-resistant diamond pattern surface.
- Solid one piece platform surface construction.

Model: **ATP-2436**
 Platform: 24" x 36"
 Weight: 32 lbs

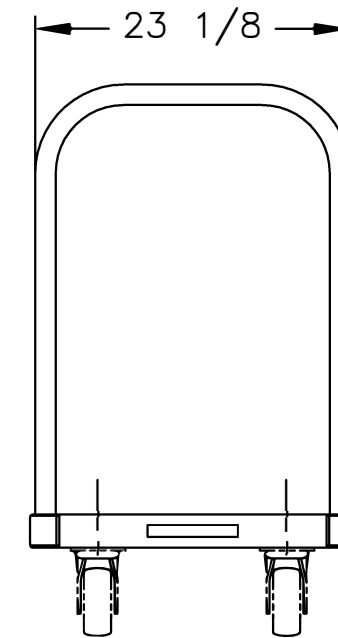
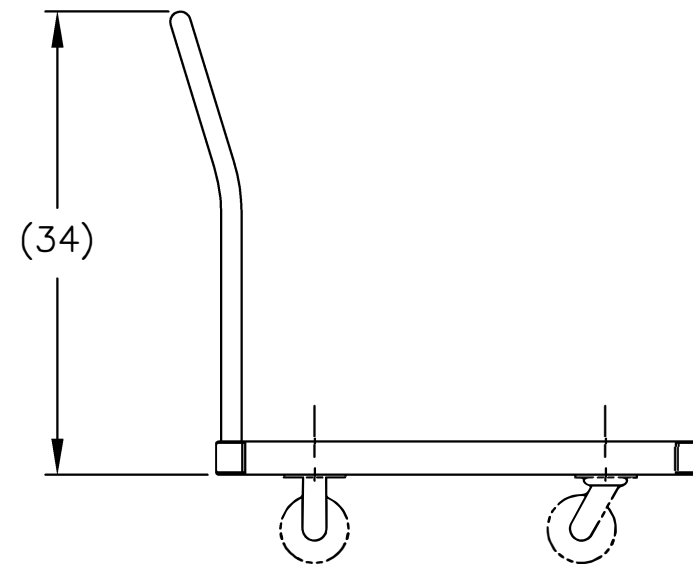

PRINT ISSUED

OCT. 27, 2006

The **CARY COMPANY**
 Est. 1895

REV. ECN & DATE APP

REVISIONS

PART NAME		DRAWN: SKH 7-29-94	
ATP-2436		CHECKED:	
		APP. ENGR.	
TOLERANCE UNLESS OTHERWISE SPECIFIED			
FRACTION	3 PLACE DECIMAL	2 PLACE DECIMAL	SCALE: 1" = 14"
± 1/64	± .005	± .01	B- 350036 REV
ANGULAR ± 1-1/2'	SHEET 1	OF 1	
BREAK ALL SHARP EDGES AND REMOVE ALL BURRS			